



ALSTOM UBUNYE

| | | | | | | | | | |
|-----------------|---------|-------------------------|--|--|--|--|--|--|--|
| Serial number : | CVS 437 | Production Order number | | | | | | | |
|-----------------|---------|-------------------------|--|--|--|--|--|--|--|

| Actions and verifications | checked | re-checked | Def. Type | | | |
|--|-------------|-------------|-----------|---|---|---|
| | OK / Not OK | OK / Not OK | A | B | C | D |
| DOCUMENTS | | | | | | |
| Presence of production self inspection reports completed (S/N), dated and signed | OK | | | | | |
| Serial number captured | OK | | | | | |
| All Aleas closed on the system | OK | | | | | |
| GENERAL APPEARANCE | | | | | | |
| Cleanliness / deburring / chips / filings / wastes / dust / screw / washers / rivets | OK | | | | | |
| Appearance of paintwork / retouches / inclusions / splinters / scratches / missed bits | OK | | | | | |
| Appearance of sheet metalwork / dents / self-tapping screws fastening | OK | | | | | |
| Information plate - QR Code | OK | | | | | |
| Fastening / maintaining of seals (sharp edge protection / integrity) | OK | | | | | |
| Visibility of S/N of components | OK | | | | | |
| MOUNTING | | | | | | |
| Presence and correct tightening of air vents (by hand, the 2 parts of the air vents must move together) | OK | | | | | |
| Fasteners: Zn-Cr / at least 2 threads / flat and striated tapered washer / slit locking nut | OK | | | | | |
| Tightening of all assembly fasteners and miscellaneous fastenings (S) | OK | | | | | |
| Sealing: Rivets, joints (including position and alignment), position of 1/4 turns. | OK | | | | | |
| Correct maintaining of all components | OK | | | | | |
| Adjustment of the batten pressing the copper-plated earthing springs on the Agate (2) | OK | | | | | |
| Sample torque verification on high voltage cables and mark with orange colour | | | | | | |
| WIRING | | | | | | |
| Check of crimping / connections (Faston lugs / pins / strands / insulator) and maintaining of the connectors (S) | OK | | | | | |
| Presence and correct connection of grounds and cleats / use of contact grease (S) | OK | | | | | |
| Screwed on assemblies: stacks / orientation of mounting / tightening to torque / marking (S) | OK | | | | | |
| Tightening of cable-glands (presence of multi-passage rings if need be) | OK | | | | | |
| Condition of cables : wires (damaged / no contact with sharp ends of ducts and/or rivets etc.) | OK | | | | | |
| Wiring: respect for minimum radii of curvatures and lengths / no loops or chewing | OK | | | | | |
| Cable fasteners: fastening correct | OK | | | | | |
| Check the mobility of the components if necessary: switches / circuit-breakers / HARTING connectors, etc. | OK | | | | | |
| Presence of protective measures against direct contacts: HV protective duct / plexi etc. | OK | | | | | |
| Presence and correct of modules: inverter / battery charger / diode | OK | | | | | |
| Correct connection of shields + condition (no overheating) | OK | | | | | |
| Legibility of sleeve markings | OK | | | | | |
| Presence and application of labels (flat and straight) | OK | | | | | |
| Check that the Ethernet cable is properly crimped and does not turn on the connector | OK | | | | | |
| Check the positioning of all riveted labels with respect to the drawing. ⁽¹⁾ | OK | | | | | |

Comments

| |
|--|
| |
| |
| |

IN THE EVENT OF NON-CONFORMITY, ATTACHE THE NON-COMPLIANT EQUIPMENT LABEL ON THE PRODUCT

| | | | | | | |
|--------------|------------------|------|------------|---------------|-----------|----------|
| AU inspector | Mapule Mphahlele | Date | 11/07/2020 | (OK / Not OK) | Signature | <i>B</i> |
| AG inspector | | Date | | OK / Not OK | Signature | |



|  | | IDENTIFICATION & SERIALIZATION LIST | | | | | | | |
|---|-------------------|-------------------------------------|--------------------------|---|---|--------------------|---|---|---|
| | | REVISION LEVEL: | | | A | B | C | D | I |
| | | K | L | M | N | S | T | | |
| | | U | V | W | X | | | | |
| Equipment Code | Serial Number | Equipment Description | | | | Serialization Date | | | |
| DTR0009706586 | CVS0437 | CVS | | | | 2024/07/11 | | | |
| Component Code | Serial Number | Qty | Rev. | Description | Drawing No. / Ref on Electrical Drawing | | | | |
| AK00001506534 | CVS46-2 | 1 | | Serial number of SIV | | | | | |
| AK00001536742 | 02/23-271 | 1 | L | Metal work - Frame | | | | | |
| DTR0000332475 | 444 | 1 | F0050/0 | Input inductance 1 mH | LFL | | | | |
| DTR0000265183 | 2T8408807 | 1 | | EMC capacitor 1µF 5% 800 V | CAP(HF)ENT-CVS | | | | |
| DTR0000201111 | | 1 | | EMC damping resistor 1 Ohm / 25W | R(HF)ENT-CVS | | | | |
| DTR0000208180 | 2403MP1208016 | 1 | A | Input contactor LTTH H01001 | LIK | | | | |
| DTR0000335747 | 2403mp21176002 | 1 | | Inrush contactor LTCH 00601 | CCK | | | | |
| DTR0009902856 | | 1 | | Inrush resistor 270 Ohm/ 900W / C52T | CCZ | | | | |
| DTR0000099777 | S8220480058 | 1 | | Transducer input voltage LEM LV 100 - 4000 / SP6 | LVMD | | | | |
| DTR0000341946 | IEC61071 | 1 | A | Input capacitor 1mF/4000Vdc | C1 | | | | |
| DTR0000386590 | 136052 | 1 | A | Discharge resistor (input capacitor) High power resistor UPX600 200K 10% | R1 | | | | |
| DTR0000386590 | 136052 | 1 | A | Discharge resistor (input capacitor) High power resistor UPX600 200K 10% | R2 | | | | |
| DTR0009706531 Ref: AK00001587464 | RID03224 | 1 | E | Inverter module | IM-CVS | | | | |
| DTR0009706531 Ref: HH00000095839 | NA | 1 | F | | | | | | |
| DTR0000332569 | PK0001375/04-0343 | 1 | F0049/1 or F0091/0 | Main transformer F0049/1 | IOT | | | | |
| DTR0000339635 | K7013mp1053010 | 1 | B | Three phase capacitor 3 x 950 µF | IOFC | | | | |
| DTR0000334580 | 2210MP654832 | 1 | | Disable contactor GND LTC001001*B00/110/2 | NPK | | | | |
| DTR0000338528 | 553 | 1 | A | Discharge resistor ATE PR102 (2 x 280k) | R1(IOFC) R2(IOFC) | | | | |
| DTR0000332748 | | 1 | | Disable contactor IOFC2 AF95B-30-11RT 48-130V | FCK | | | | |
| DTR0000157988 | | 1 | | Current transformer measure TC40 600/1 15VA classe 1 | AOCMD.L1 to L3 | | | | |
| DTR0000157388 | | 1 | | Current transformer measure TC40 200/1 6VA classe 1 | IOCMD.L1 to L3 | | | | |
| DTR0000113561 | 722112000657 | 1 | | Voltage transducer output 400Vac LV 25-600/SP1 | AOVMD1 | | | | |

| | | | | | |
|---------------|------------------|---|--------|---|--------------------|
| DTR0000113561 | 721272000570 | 1 | | Voltage transducer output 400Vac LV 25-600/SP1 | AOVMD2 |
| DTR0000334139 | 6094741 | 1 | | Output contactor TRI LC1F150 | AOIK |
| DTR0000265183 | 1.A.8.922839 | 1 | | EMC capacitors 1µF / 800 V | C9 |
| DTR0000265183 | 1.A.8.922839 | 1 | | EMC capacitors 1µF / 800 V | C10 |
| DTR0000265183 | 1.A.8.922839 | 1 | | EMC capacitors 1µF / 800 V | C11 |
| DTR0000265183 | 1.A.8.922839 | 1 | | EMC capacitors 1µF / 800 V | C12 |
| DTR0000168847 | | 1 | | EMC discharge resistors 2 x 1 Mohm RCEC ISO 25 F | R3-R4 |
| AK00001621435 | RID03440 | 1 | F | Battery charger module | BCM |
| DTR0000367127 | PK0001375-030138 | 1 | A C | Input inductance battery charger 4RDUKE287 25 µH / 265A | BCL |
| DTR0000265183 | 1.A.8.922839 | 1 | | EMC capacitors 1µF / 800 V | C13 |
| DTR0000265183 | 1.A.8.922839 | 1 | | EMC capacitors 1µF / 800 V | C14 |
| DTR0000265183 | 1.A.8.922839 | 1 | | EMC capacitors 1µF / 800 V | C15 |
| DTR0000265183 | 1.A.8.922839 | 1 | | EMC capacitors 1µF / 800 V | C16 |
| DTR0000168847 | 2003 | 1 | | EMC discharge resistors 2 x 1 Mohm RCEC ISO 25 F | R5,R6 |
| DTR0000350394 | IEC60209-4 | 1 | | Fuse 315A - 690V 20 212 34.315 | BCOF |
| DTR0000212580 | 2106mP0652019 | 1 | | Disable load DC contactor LTC250 - version 110V | BCOK |
| DTR2000000099 | JQ10473 | 1 | A | AGATE Aux 3 Smart | AA3S |
| AK00001719755 | Na | 1 | | Structure d'accueil AA3S | |
| DTR0000267606 | 1010996200013 | 1 | | Alimentation DM1618-OR (44 V ----> 220V/ 24V) | CM-AL110/24-CVS |
| DTR0000262019 | 1012696400012 | 1 | | Alimentation EQ2544-OR (65....150V =>15 V) | CM-AL110/15-CVS |
| DTR0000368243 | Na | 1 | | Circuit breaker 3A 1P D-2AA5X1HCl0300KXB- XXXXXBFVAX1-X | CC(AL)ACU |
| DTR0000368240 | Na | 1 | | Circuit breaker 5A 1P D-2AA5X1HBI0500KXB- XXXXXBFVAX1-X | CC(ALS) |
| DTR0025731525 | | 1 | | Relay "H400" 326 404 XUU 110V | K1, K2, K3, K4, K5 |
| DTR00267348BU | | 1 | | Time delay relay 326 004 MTE H SOS 110VCC YXY or TERS6B1ATYXY | K6 |
| DTR0000351873 | PK00011730382 | 1 | A | Motoventilator 400V 50 Hz | FAN |
| DTR0000368242 | Na | 1 | | Circuit breaker MAG-HYD 6A 3P D-2AAMX3QAH0600KXB- XXXXXWVFA11-X | FANP |
| DTR0000277366 | 60947-2 | 1 | | FAN Contactor AF16ZB-30-10RT-22 AF16ZB 48/130V | KFAN |
| DTR0000267207 | | 1 | | Analog detect air flow 4-20mA FCS-M18-LIX/D241 | CCA(DB-VT)CVS |

| | | | | | |
|---------------|---------|---|--|--|-------------|
| 4RDSPE251 | 60947-2 | 1 | | Transformer 3 P 300VA - version 110 V | FBST |
| DTR0000255012 | | 1 | | Contactor 4 P LC1 DT80AFD | SHSK |
| DTR0000111663 | | 1 | | Phase detector relay CM-MPS 41S - 1SVR730884R3300 | PHR |
| DTR0000255312 | | 1 | | Inrush contactor LC1 D65AFD | CCK2 |
| DTR0000111644 | 60936 | 1 | | Fuse holder FH3P | SHSF |
| DTR0009902852 | | 1 | | Inrush resistor shore supply C52T - 5,6 Ohm 900W - 5% | CCZ2-R to T |

| | | | | |
|---|--------------|------------------------------|--|---|
|  | Page 1 of 46 | CODE DTR0000970658 | FINAL TEST CERTIFICATE AU_CVS 437 | DTR0100034034 Rev: C |
|---|--------------|------------------------------|--|---|

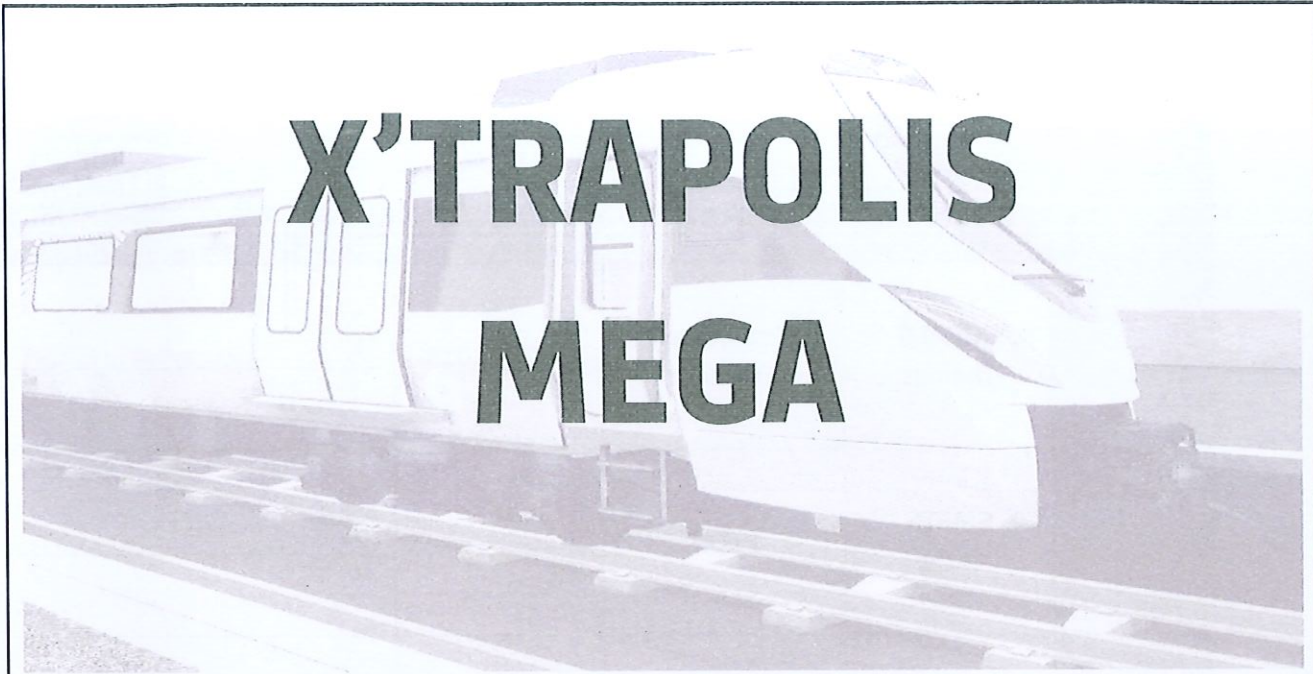



X'TRAPOLIS MEGA

PROCEDURE AND TEST REPORT

CONFIDENTIAL INFORMATION

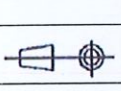
This document and the information contemplated therein have to be considered as Confidential Information pursuant to the provisions of Clause 25 of the MSA, and treated as such.

| | | | | | | | |
|---|---------------------------------|----------------------|------|---|------|---------------|--|
| RELEASED | | | | Application: PRASA | | | |
| Technical Modifications | | Geometric tolerances | | A4 | N | | |
| H1 | IGBT Test update | | | 1.1.8 | | | |
| H0 | Global Update after transfer SA | | | | | | |
| GO | Update for PC104 & V3.0.0 | | | | | | |
| F0 | Update for R1 & R2 | | | | | | |
| E0 | Update for dashboard test | | | Replaces: | | Replaced by : | |
| Do | Update for AAUX3S | | | | | | |
| CO | Update and translation | | | | | | |
| BO | Update | | | | | | |
| AO | Creation | | | | | | |
| Index | Revision Notification no. | | | | | | |
|  | | Date | Name | PRASA Auxiliary converter Routine test - Procedure and report | | | |
|  | | en | | | | | |
| | | | | DTR0100036745 | 1/46 | | |

| | | | | |
|---|---------------------|-------------------------------|--|---------------------------------|
|  | <p>Page 2 of 46</p> | <p>CODE DTR0000970658</p> | <p>FINAL TEST CERTIFICATE AU_CVS 437</p> | <p>DTR0100034034 Rev: C</p> |
|---|---------------------|-------------------------------|--|---------------------------------|

Internal Validation

| | Name | Function | Date | Signature |
|----------|-------------------|----------------------------|------------|-------------------------------|
| Writer | ROBALO Thomas | Method test Engineer | 30/09/2019 | <p>X</p> <hr/> Robalo Thomas |
| Checker | SMETS Cathy | PrEM | | <p>X</p> <hr/> Smets Cathy |
| AQ | BOGATYREV Ilya | Project Quality Manager | 30/09/2019 | <p>X</p> <hr/> Bogatyrev Ilya |
| Approver | RENARD Bruno | Sub-System Manager | | <p>X</p> <hr/> Renard Bruno |
| Edit | Suzan Mnisi | Test Engineer | 20/09/2021 | |
| Edit | Shiko MATLALA | Test Engineer | 07/07/2022 | |

| | | | | |
|---|---|--|--|--|
|  | <p align="center">Page 3 of 46</p> | <p align="center">CODE DTR0000970658</p> | <p align="center">FINAL TEST CERTIFICATE AU_CVS 437</p> | <p align="center">DTR0100034034 Rev: C</p> |
|---|---|--|--|--|

Table of Contents

| | | |
|--------|---|------------------------------|
| 1 | PURPOSE / But | 5 |
| 2 | Check the information of QR CODE / Vérification de l'information du QR CODE. | 6 |
| 2.1 | Scan the QR code label and verify the conformity with the name plate. Scanner le QR code et vérifier la concordance des informations avec ceux de la plaque signalétique..... | 6 |
| 3 | REFERENCE documents / Documents de référence | 6 |
| 4 | GENERAL TEST conditions / Condition générales de tests | 7 |
| 4.1 | Configuration of SIV under test / Configuration du CVS en test..... | 7 |
| 4.2 | Test location / Lieu du test | 7 |
| 4.3 | Test participants / Participants aux tests..... | 7 |
| 5 | Visual inspection / Inspection visuelle | 8 |
| 5.1 | Mechanical general aspect with covers. Aspect mécanique général avec ses couvercles..... | 8 |
| 5.2 | Mechanical general aspect without covers / Aspect mécanique général sans couvercles..... | 8 |
| 5.3 | Electrical general aspect and marking / Aspect général électrique et marquage..... | 9 |
| 5.4 | Identification and warning label / Identification des pictogrammes danger. | 10 |
| 5.5 | Coding connectors / Codage des connecteurs | 10 |
| 5.6 | Electrical continuity / Continuité électrique..... | 12 |
| 5.7 | Insulation resistance and dielectric test / Résistance d'isolement et test diélectrique..... | 13 |
| 5.8 | Verify the value of the resistors / Vérification de la valeur des résistances..... | 16 |
| 5.9 | Circuit breaker check / Vérification des disjoncteurs | 17 |
| 5.10 | Fuses check / Vérification des fusibles..... | 17 |
| 5.11 | Relay PHR setup / Réglages du PHR. | 17 |
| 5.12 | Off power tests / Tests à blanc..... | 18 |
| 5.12.1 | CHECKING POWER OF TRANSDUCERS / VERIFICATION ALIMENTATION DES TRANSDUCTEURS..... | 18 |
| 5.12.2 | PROGRAMMING CONTROL UNIT / PROGRAMMATION DE L'ÉLECTRONIQUE DE CONTRÔLE. | 19 |
| 5.12.3 | CHECKING OF LOGICAL INPUTS AND OUTPUTS / VÉRIFICATION DES ENTRÉES ET SORTIES LOGIQUES..... | 21 |
| 5.12.4 | IGBT PULSES TEST / VÉRIFICATION DES IMPULSIONS IGBT | 24 |
| 5.12.5 | IES TEST ONLY WITH SOFTWARE> V3.0.0/ TEST IES SEULEMENT AVEC SOFTWARE > V3.0.0 | 30 |
| 5.13 | Light load high voltage test / Essais haute tension et faible charge | 30 |
| 5.13.1 | BEFORE STARTING / AVANT DE DÉMARRER | 30 |
| 5.13.2 | BACKUP MODE CHECK / VÉRIFICATION DU MODE BACKUP | 32 |
| 5.13.3 | REVERSIBLE MODE CHECK / VÉRIFICATION DU MODE RÉVERSIBLE | 36 |
| 5.13.4 | SHORE SUPPLY MODE CHECK / VÉRIFICATION DU MODE PRISE DE QUAI | 38 |
| 5.13.5 | FLAT BATTERY START CHECK / VERIFICATION DEMARRAGE SOUS BATTERIE BASSE | 41 |
| 5.14 | Safety requirements / Exigences de sécurité..... | 42 |
| 5.14.1 | INPUT AND OUTPUT CAPACITOR DISCHARGE DÉCHARGE DES CONDENSATEURS D'ENTRÉE ET SORTIE..... | 42 |
| 5.14.2 | GROUND CONTINUITY TEST / TEST DE CONTINUITÉ DES MASSES. | 43 |
| 6 | Identification sheet / Feuille d'identification | 46 |
| 7 | List of measuring devices used / Liste du matériel utilisé | Error! Bookmark not defined. |
| 8 | APPENDIX / Annexe | Error! Bookmark not defined. |

| | | | | |
|---|------------------------------------|---|---|--|
|  | <p align="center">Page 4 of 46</p> | <p align="center">CODE DTR0000970658</p> | <p align="center">FINAL TEST CERTIFICATE AU_CVS 437</p> | <p align="center">DTR0100034034 Rev: C</p> |
|---|------------------------------------|---|---|--|

8.1 Appendix B - Dielectric test procedure / Annexe B – Procédure du test diélectrique **Error! Bookmark not defined.**

8.1.1 CIRCUIT A: HIGH VOLTAGE CIRCUIT (3KV) / CIRCUIT A: CIRCUIT HAUTE TENSION (3KV)... **ERROR! BOOKMARK NOT DEFINED.**

8.1.2 CIRCUIT B: MEDIUM VOLTAGE CIRCUIT (400VAC)/ CIRCUIT B: CIRCUIT MOYENNE TENSION (400VAC) **ERROR! BOOKMARK NOT DEFINED.**

8.1.3 CIRCUIT C : LOW VOLTAGE AND CONTROL CIRCUIT (110V) / CIRCUIT C: CIRCUIT BASSE TENSION (110VDC) **ERROR! BOOKMARK NOT DEFINED.**

8.1.4 CIRCUIT D : LOW VOLTAGE CONTROL CIRCUIT (<36V OR NETWORK) / CIRCUIT D: BASSE TENSION (<36V OU RÉSEAU) **ERROR! BOOKMARK NOT DEFINED.**



8.1.5 CIRCUIT E : LOOP FIRE/ CIRCUIT INCENDIE..... **ERROR! BOOKMARK NOT DEFINED.**

List of measuring devices used / Liste du matériel utilisé

| Equipment name <i>Nom équipement</i> | Type <i>Type / Marque</i> | Ref number <i>N° reference Alstom</i> | Next calibration date <i>Date prochaine calibration</i> |
|---|-------------------------------------|---|---|
| Megger equipment <i>Megger</i> | FLUKE 1550C-5KV | 381963 | Sep-24 |
| Flash test equipment <i>Poste de rigidité</i> | EATON | 107563 | Sep-24 |
| Multimeter <i>Multimètre</i> | FLUKE-287 | 3563062 | Sep-24 |
| Oscilloscope <i>Oscilloscope</i> | TEKTRONIX | C05196 | Sep-24 |
| AC current measuring device <i>Pince de courant AC</i> | DISPLAY PANEL | DTR01000043228 | Sep-24 |
| DC current measuring device <i>Pince de courant DC</i> | DISPLAY PANEL | DTR01000043228 | Sep-24 |
| Phase rotation test device <i>Afficheur champ tournant</i> | TT1 (TG315) | 493240 | Sep-24 |
| Wattmeter <i>Wattmètre</i> | FLUKE-9063 | 412096105 | Dec-24 |
| Earth Continuity tester | KIKUSUI | YG006883 | Sep-24 |

| | |
|--|--|
| <p align="center">Name – Address of testing centre <i>Nom – Adresse du centre de test</i></p> | <p align="center">Name – Customer address <i>Nom – Adresse client</i></p> |
|--|--|

| | | | | |
|---|---|--|--|--|
|  RESTRICTED  | <p align="center">Page 5 of 46</p> | <p align="center">CODE DTR0000970658</p> | <p align="center">FINAL TEST CERTIFICATE AU_CVS 437</p> | <p align="center">DTR0100034034 Rev: C</p> |
|---|---|--|--|--|

| | |
|---|--|
|  ALSTOM UBUNYE 1 4TH LN, VOSTERKROON, NIGEL, 1490 (SOUTH AFRICA) |  1040 BURNETT STREET PRASA HOUSE HATFIELD (SOUTH AFRICA) |
|---|--|

1 PURPOSE / But

This document describes the routine test which will be carried out on the PRASA Auxiliary converter in Alstom Charleroi Factory.

Ce document décrit les tests de série qui sont réalisés sur le convertisseur auxiliaire PRASA dans les locaux du fabricant Alstom Charleroi.

Tests to be performed: / Tests à réaliser:

- Visual inspection (general aspect, identification and warning labels) / *Inspection visuelle (Aspect général, identification et marquage danger).*
- Marking inspection / *Vérification des différents labels.*
- Electrical continuity / *Continuité électrique.*
- Check the insulation resistance test and dielectric test / *Vérification de la résistance d'isolement et diélectrique.*
- Off-power test (check I/O and pulses of the IGBT) / *Tests à blanc (verification des entrées / sorties et impulsions IGBT).*
- Light load test / *Test à faible puissance.*
 - o In a matter of different characteristics / *Relevé des différentes caractéristiques de sortie.*
 - o Check phase rotation / *Vérification du champ tournant.*
 - o Check Fan rotation / *Vérification du sens de rotation du GMV.*
 - o Safety requirements / *Exigences de sécurité (décharge des condensateurs et test de continuité des masses).*
- Check the reversible mode / *Vérification du mode réversible.*
- Check the shore supply mode / *Vérification de la prise de quai.*

| | | | | |
|---|---------------------|-------------------------------------|--|---------------------------------------|
|  | Page 6 of 46 | CODE DTR0000970658 | FINAL TEST CERTIFICATE AU_CVS 437 | DTR0100034034 Rev: C |
|---|---------------------|-------------------------------------|--|---------------------------------------|

2 Check the information of QR CODE / Vérification de l'information du QR CODE.

2.1 Scan the QR code label and verify the conformity with the name plate.

Scanner le QR code et vérifier la concordance des informations avec ceux de la plaque signalétique

For this test, you can use a QR code reader like a TYPE SG20B or simply a smartphone.

Cette operation peut être effectuée avec un lecteur de code barre de type SG20B ou avec un smartphone.

The QR Code is giving the following informations:

Le QR code est composé des informations suivantes:

Part Number DTR – Product description – Serial number

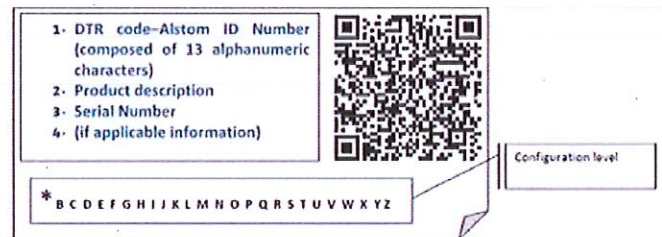

The encoded informations are: / *les informations encodées sont :*

| Item | Information of name plate <i>Informations de la plaque signalétique</i> | Information of QR Code <i>Informations du QR CODE</i> | Passed / Correct <i>(OK / NOK)</i> |
|---------------------|--|--|---------------------------------------|
| Part Number DTR | DTR0000970658 | DTR0000970658 | OK |
| Product description | STATIC CONVERTER | STATIC CONVERTER | OK |
| Serial number | AU_CVS_0437 | AU_CVS_0437 | OK |

3 REFERENCE documents / Documents de référence

| Description <i>Description</i> | Reference <i>Référence</i> | Revision or date <i>Révision ou date</i> | s |
|--|-------------------------------|---|-----|
| Routine test specification <i>Spécification essais de série</i> | DTR0100032746 | C | All |
| Configuration Follow up document <i>Document de configuration CVS</i> | DTR0100034034 | C | All |

| | | | | |
|---|--------------|-------------------------------------|--|---|
|  | Page 7 of 46 | CODE DTR0000970658 | FINAL TEST CERTIFICATE AU_CVS 437 | DTR0100034034 Rev: C |
|---|--------------|-------------------------------------|--|---|

4 GENERAL TEST conditions / Condition générales de tests

4.1 Configuration of SIV under test / Configuration du CVS en test.

| ARTICLE NUMBER: <i>NUMÉRO ARTICLE:</i> | | DTR0009706586 | | | | | | |
|--|---|----------------------|---|---|---|---|---|--|
| SERIAL NUMBER: <i>NUMÉRO DE SÉRIE:</i> | | | | | | | | |
| | | CONFIGURATION | | | | | | |
| Mechanical drawing <i>Schéma mécanique</i> AK00001506534 | A | B | C | D | E | F | G | |
| | X | I | J | K | L | M | N | |
| | O | P | Q | R | S | T | U | |
| | V | W | X | Y | Z | | | |
| Wiring diagram <i>Schéma électrique</i> AKD0001541369 | A | B | C | D | E | F | G | |
| | H | I | J | K | L | M | X | |
| | O | P | Q | R | S | T | U | |
| | V | W | X | Y | Z | | | |

4.2 Test location / Lieu du test

MANUFACTURER: 

FACTORY UNIT:

**1 4TH LN, VOSTERKROON
 NIGEL, 1490
 (SOUTH AFRICA)**

We certify that, the above equipment has been manufactured in conformity with the project technical specification, and all inspection operations carried out, following the routine test specification DTR0100032746.

Nous certifions que, la fourniture citée a été fabriquée conformément aux spécifications techniques du marché, et que toutes les opérations de contrôle et essais effectuées, elle répond sous tous ses aspects, à la spécification DTR0100032746.

4.3 Test participants / Participants aux tests

| DEPARTMENT <i>Département</i> | NAME (S) <i>Nom(s)</i> | Function <i>Fonction</i> | DATE <i>Date</i> | RESULTS |
|--------------------------------------|-------------------------------|---------------------------------|-------------------------|----------------|
| ALSTOM UBUNYE TRACTION | LUCKY KGWADI | PRE-TEST INSPECTION | 07/07/2024 | PASSED |
| | THABO SISHANGE | | | |

| | | | | |
|---|---|--|--|--|
|  | <p align="center">Page 8 of 46</p> | <p align="center">CODE DTR0000970658</p> | <p align="center">FINAL TEST CERTIFICATE AU_CVS 437</p> | <p align="center">DTR0100034034 Rev: C</p> |
|---|---|--|--|--|

5 Visual inspection / *Inspection visuelle*

5.1 Mechanical general aspect with covers.

Aspect mécanique général avec ses couvercles

| Test / <i>Test</i> | Passed / Failed (OK / NOK) |
|--|-------------------------------|
| Mechanical aspect (Earth stuts, shunt strap, torque marks on bolts and nuts) <i>Aspect mécanique</i> | OK |
| Check the color aspect of the case <i>Vérifier l'aspect de la couleur</i> | OK |
| Check the position of external covers <i>Vérifier le bon positionnement des couvercles extérieurs</i> | OK |
| Gaskets (seal and position are satisfying) <i>Joints (étanchéité et position correcte)</i> | OK |
| Visual checking of visible seals (Capacitors and resistors) <i>Vérification visuelle des joints d'étanchéité et des presses-étoupes</i> | OK |
| Air inlets and outlets are clean, neither damaged nor blocked <i>Entrées et sortie d'air sont propres, sans dommages et ne sont pas bouchées</i> | OK |
| Presence of "water drop" under the case <i>Vérifier la présence des "gouttes d'eau" sous le coffre</i> | OK |
| Panels hindering the access to high voltage parts are mounted properly <i>Les panneaux montés devant l'accès à la haute tension sont montés correctement.</i> | OK |
| Access panels can be opened, closed and locked properly <i>Les panneaux d'accès peuvent être ouverts, fermés et bloqués correctement</i> | OK |

5.2 Mechanical general aspect without covers / Aspect mécanique général sans couvercles

| Test / <i>Test</i> | Passed / Failed (OK / NOK) |
|--|-------------------------------|
| Equipment's fixation and condition <i>Vérifier la fixation des équipements et leur état</i> | OK |
| Each equipment is securely restrained and not liable to be damaged by movement <i>Chaque équipement est solidement fixé et ne peut être endommagé par un mouvement</i> | OK |
| Check the absence of any mix of materials with the assembly screws, flats, nuts (Inox, steel etc..) <i>Vérifier l'absence de mélange de matières des assemblages mécaniques, vis, rondelles, écrous (Inox, acier etc..)</i> | OK |
| Fan is not obstructed and can rotate without friction <i>Ventilateur n'est pas obstrué et tourne librement</i> | OK |
| Ventilation shield are properly mounted <i>Les écrans dans la ventilation sont montés correctement.</i> | OK |
| Check the absence of any foreign object in the case <i>Vérifier l'absence de corps étranger dans le coffre</i> | OK |
| Check the presence of the foam gasket above the transformer. The screen of the transformer must come in position on the gasket | OK |

| | | | | |
|---|---|--|--|--|
|  | <p align="center">Page 9 of 46</p> | <p align="center">CODE DTR0000970658</p> | <p align="center">FINAL TEST CERTIFICATE AU_CVS 437</p> | <p align="center">DTR0100034034 Rev: C</p> |
|---|---|--|--|--|

| Test / Test | Passed / Failed (OK / NOK) |
|---|----------------------------|
| <i>Vérifier la présence du joint en mousse au-dessus du transformateur. L'écran doit être positionné sur le joint.</i> | |
| Check the presence of the foam gasket under the transformer (on the cover). <i>Vérifier la présence du joint en mousse sous le transformateur (sur le couvercle du bas)</i> | OK |
| Check the presence of the foam gasket positioned on covers underneath both modules. <i>Vérifier la présence des joints en mousse positionné sur les couvercles en dessous des deux modules</i> | OK |
| Check the presence of mounting brackets at the foot of the screen of the transformer <i>Vérifier la présence des équerres de fixation au bas de l'écran du transformateur</i> | OK |

5.3 Electrical general aspect and marking / Aspect général électrique et marquage.

| Test / Test | Passed / Failed (OK / NOK) |
|---|----------------------------|
| All electrical connections must have at least 2.0 turn free threads and have been marked when torque tightened <i>Toutes les connexions électriques doivent avoir au moins 2 filets libre après écrou ainsi qu'un marquage pour serrage au couple.</i> | OK |
| Visual check of earth studs <i>Vérifier visuellement les points de masse</i> | OK |
| All ground connections are correctly identified with potential on all terminals <i>Toutes les connexions de masses sont correctement identifiées avec leur potentiel.</i> | OK |
| Check the equipment's fixation <i>Fixation des éléments</i> | OK |
| Marking sleeves (yellow with potential and designation, no classes indicated) <i>Marquage des fils par des manchons jaune (indication du potentiel et désignation mais la classe n'est pas indiquée).</i> | OK |
| Cable and copper bars section <i>Section des câbles et barres</i> | OK |
| Check crimping <i>Sertissage des cosses</i> | OK |
| No cables on sharp edges or presence of protection when it's needed <i>Pas de câbles sur des arêtes ou bien la présence de protection si nécessaire</i> | OK |
| Segregation of HV / MV and LV cables <i>Ségrégation respectée entre les câbles HT / MT et BT</i> | OK |
| Check of LHD loop fire path (no cracking, no defect) <i>Vérification du fil incendie (Pas de craquelure et pas de dommage)</i> | OK |
| Check if the pins are properly inserted in the connectors and stay in place <i>Vérifier que les contacts sont correctement insérés dans les connecteurs et qu'ils restent en place</i> | OK |

| | | | | |
|---|--|--|---|--|
|  | <p align="center">Page 10 of 46</p> | <p align="center">CODE DTR0000970658</p> | <p align="center">FINAL TEST CERTIFICATE AU_CVS 437</p> | <p align="center">DTR0100034034 Rev: C</p> |
|---|--|--|---|--|

5.4 Identification and warning label / Identification des pictogrammes danger.

| Test / Test | Passed / Failed (OK / NOK) |
|--|----------------------------|
| Check that all labels are correctly according to the drawings <i>Vérifier que tous les pictogrammes sont conformes aux plans.</i> | OK |
| Components labelling <i>Vérifier la présence de l'identification de chaque composant.</i> | OK |
| Check presence of Alstom's plate <i>Vérifier la présence de la plaque firme et de la plaque signalétique.</i> | OK |

5.5 Coding connectors / Codage des connecteurs

Check that the presence of the coding pins on the following connectors:
Vérifier que les connecteurs suivants ont le codage correct.

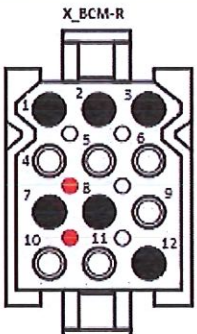
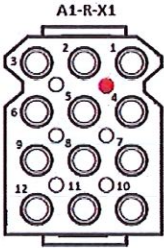
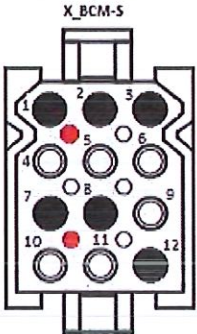
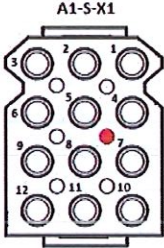
| Connectors of CVS <i>Codage connecteurs du CVS</i> | Connectors on Battery charger module <i>Codage connecteurs du module chargeur de batterie</i> | Passed / Failed (OK / NOK) |
|---|--|----------------------------|
|  |  | OK |
|  |  | OK |

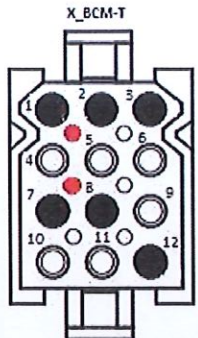
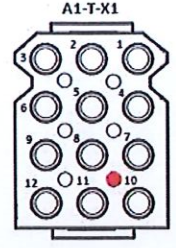
| | | |
|---|--|-----------|
|  |  | <p>OK</p> |
|---|--|-----------|

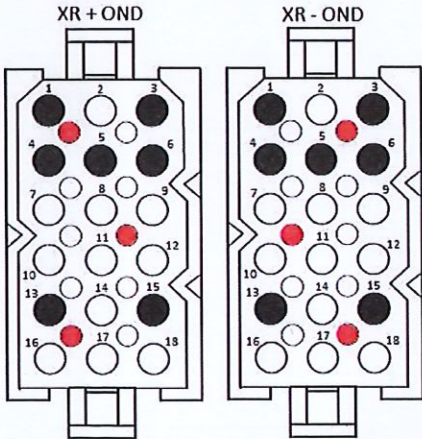
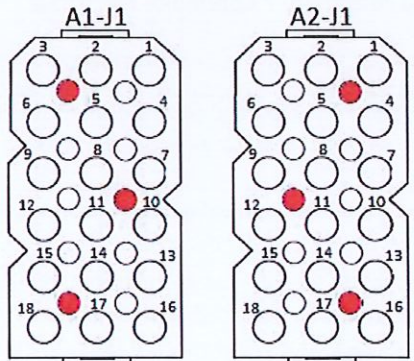
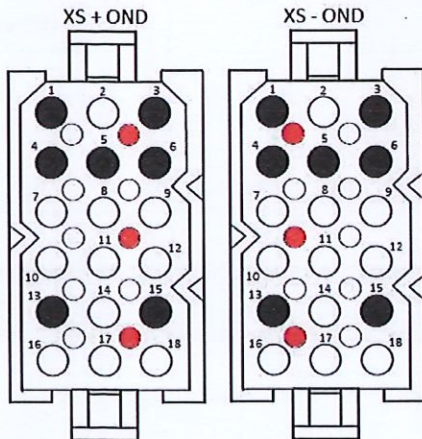
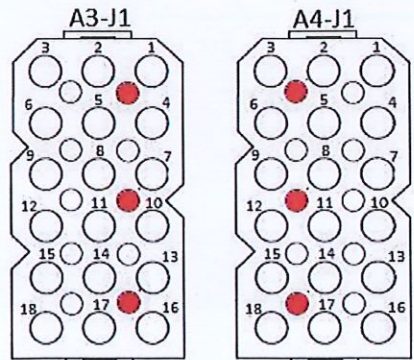

| Connectors of SIV <i>Codage connecteurs du CVS</i> | Connectors on inverter module <i>Codage connecteurs du module onduleur</i> | Passed / Failed (OK / NOK) |
|---|--|---|
|  |  | <p>OK</p> |
|  |  | <p>OK</p> |

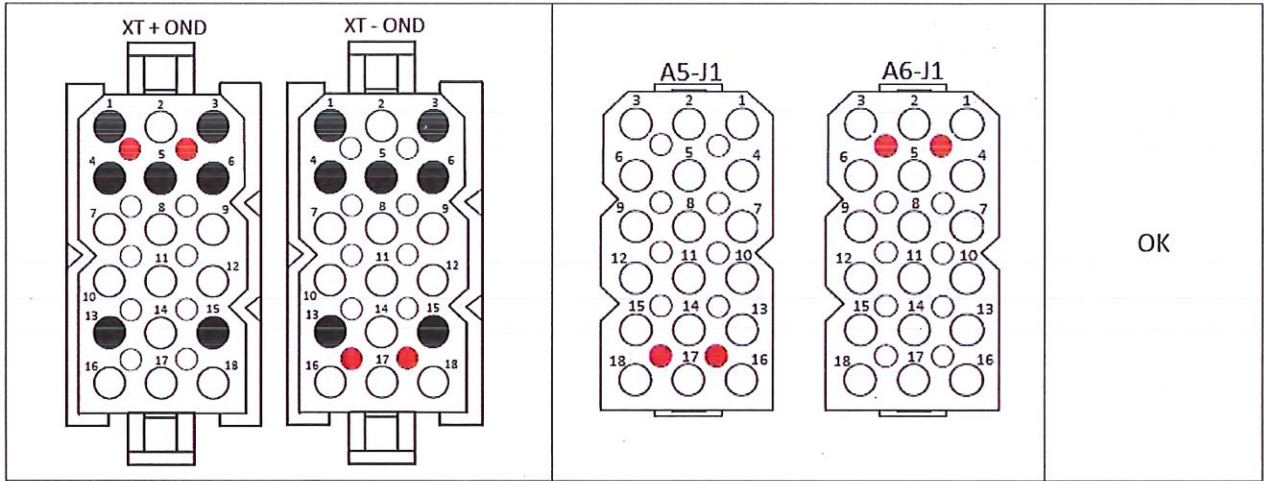
| | | | | |
|---|----------------------|-------------------------------|--|---------------------------------|
|  | <p>Page 12 of 46</p> | <p>CODE DTR0000970658</p> | <p>FINAL TEST CERTIFICATE AU_CVS 437</p> | <p>DTR0100034034 Rev: C</p> |
|---|----------------------|-------------------------------|--|---------------------------------|



OK

5.6 Electrical continuity / Continuité électrique.

| Test / Test | Passed / Failed (OK / NOK) |
|---|----------------------------|
| <p>Using a multimeter, check the electrical continuity of the auxiliary converter using the schematic. <i>Utiliser un multimètre, vérifier la continuité électrique du convertisseur auxiliaire en utilisant soit le schéma de câblage.</i></p> | PASSED |
| <p> Pay particular attention to rectifier bridges wiring : FBSR, SBD1, SBD2 <i>Attention particulière au câblage des éléments suivants: FBSR, SBD1, SBD2</i></p> | DONE |
| <p>Check the wires' colours on the Ethernet link between 18XR11_2 and X_ETHER_AA3. The colours attribution must be respected as shown on the wiring diagram <i>Vérifier la couleur des fils de la liaison Ethernet entre 18XR11_2 et X_ETHER_AA3. L'attribution des couleurs doit être respectée comme l'indique le schéma de câblage.</i></p>  | DONE |

| TEST OPERATOR | FUNCTION | RESULTS |
|-------------------|-----------------|---------|
| KHUTSO MATLEJOANE | FUNCTIONAL TEST | PASSED |
| THULANI MIYA | | |

| | | | | |
|---|---------------|-------------------------------------|--|---|
|  | Page 13 of 46 | CODE DTR0000970658 | FINAL TEST CERTIFICATE AU_CVS 437 | DTR0100034034 Rev: C |
|---|---------------|-------------------------------------|--|---|

5.7 Insulation resistance and dielectric test / Résistance d'isolement et test diélectrique.



Safety instructions for all high voltage tests
Consignes de sécurité pour tous les tests haute tension



- The CQE electrical authorization procedures apply.
Les procédures et habilitation du CQE sont d'application
- Electrical tests can only be carried out by persons with sufficient authorization who have been trained for the job.
Les tests électriques ne peuvent être réalisés que par des personnes qui détiennent une habilitation suffisante et qui ont été formées au poste de travail.
- To avoid the risk of electric shocks, ensure that all capacitors have been discharged BEFORE intervention on the tested equipment.
Afin d'éviter tout risque électrique, il faut s'assurer que les condensateurs sont déchargés avant toute intervention sur l'équipement testé.
- During flash tests, it is imperative to use a tool and the insulated gloves provided for this purpose.
Lors de l'essai diélectrique, il est impératif d'utiliser un tabouret et des gants isolants prévus à cet effet.
- The rigidity unit and the equipment tested must be connected to the ground.
L'équipement et l'appareil de rigidité doivent être connectés à la masse.
- Access to the test zone is restricted to authorized personnel.
L'accès dans la zone de test est restreint aux personnes habilitées.
- The test zone must be kept clean and tidy.
La zone de test doit être maintenue propre et ordonnée.

The dielectric procedure and the definition of the different circuit can be found in appendix B.

La procédure et la définition des différents circuits peuvent être trouvés dans l'annexe B.

- Group A: High voltage circuit (3000 Vdc)
Groupe A: Circuit haute tension (3000Vdc)
- Group B: Medium voltage (400 Vac)
Groupe B: Circuit moyenne tension (400Vac)
- Group C: Low voltage power and control (110Vdc)
Groupe C: Circuit basse tension de puissance et de commande (110Vdc)
- Group D: Screened cables (<36Vdc)
Groupe D: Câbles blindés (<36 Vdc)
- Group E: Measures, network, loop fire
Groupe E: Mesures, réseau, circuit incendie.

Group A (HV 3000Vdc) / Groupe A (HT 3000Vdc)

| | Measure <i>Mesure</i> | Passed / Failed <i>Correct et OK</i> |
|--|---------------------------------|---|
| Connect circuit B, C, D and E to the ground, Using a MEGGER set to 1000V, measure the resistance between circuit A and the ground. The reading should be: $R > 30 \text{ M}\Omega$. <i>Connecter les circuits B, C, D et E à la masse. Utiliser un Megger sur la position 1000 V, mesurer la résistance d'isolement entre le circuit A et la masse. La valeur mesurée doit être : $R > 30 \text{ M}\Omega$.</i> | 12.6GΩ | PASSED |
| Test with an AC voltage of 9.5 kVrms (50Hz) between circuit A and the ground for 1 minute. The test is considered to be satisfactory if no discharge flash or spark is observed. <i>Tester à une tension de 9,5KVrms (50Hz) entre le circuit A et la masse pendant une minute. Le test est considéré comme satisfaisant si aucun flash ou percement n'est observé.</i> | 12.6mA | PASSED |
| Repeat the measurement with the MEGGER set to 1000V. The resistance between circuit A and the ground. The reading must not vary by more than 10% from the previously measured | 826GΩ | PASSED |

| | | | | |
|---|--|--|---|--|
|  | <p align="center">Page 14 of 46</p> | <p align="center">CODE DTR0000970658</p> | <p align="center">FINAL TEST CERTIFICATE AU_CVS 437</p> | <p align="center">DTR0100034034 Rev: C</p> |
|---|--|--|---|--|

| | |
|--|--|
| <p>value. If the reading is higher, investigate and rectify <i>Répéter la mesure au Megger sur la position 1000V du circuit A par rapport à la masse. La résistance mesurée ne doit varier de plus de 10% de la mesure préliminaire. Si cette mesure est supérieure, investiguer et réparer le défaut.</i></p> | |
|--|--|

Group B (MV 400Vac) / Groupe B (MT 400Vac)

| | Measure <i>Mesure</i> | Passed / Failed <i>Correct et OK</i> |
|---|--------------------------|---|
| <p>Connect circuit A, C, D and E to the ground, Using a MEGGER set to 500V, measure the resistance between circuit B and the ground. The reading should be: $R > 10 M\Omega$. <i>Connecter les circuits A, C, D et E à la masse. Utiliser un Megger sur la position 500 V, mesurer la résistance d'isolement entre le circuit B et la masse. La valeur mesurée doit être : $R > 10 M\Omega$.</i></p> | 39.1GΩ | PASSED |
| <p>Test with an AC voltage of 2.5 kVrms (50Hz) between circuit B and the ground for 1 minute. The test is considered to be satisfactory if no discharge flash or spark is observed. <i>Tester à une tension de 2,5KVrms (50Hz) entre le circuit B et la masse pendant une minute. Le test est considéré comme satisfaisant si aucun flash ou perçement n'est observé.</i></p> | 15.4mA | PASSED |
| <p>Repeat the measurement with the MEGGER set to 500V. The resistance between circuit B and the ground. The reading must not vary by more than 10% from the previously measured value. If the reading is higher, investigate and rectify. <i>Répéter la mesure au Megger sur la position 500V du circuit B par rapport à la masse. La résistance mesurée ne doit varier de plus de 10% de la mesure préliminaire. Si cette mesure est supérieure, investiguer et réparer le défaut.</i></p> | 161GΩ | PASSED |

Group C (LV 110Vdc) / Groupe C (BT 110Vdc)

| | Measure <i>Mesure</i> | Passed / Failed <i>Correct et OK</i> |
|--|--------------------------|---|
| <p>Connect circuit A, B, D and E to the ground, Using a MEGGER set to 500V, measure the resistance between circuit C and the ground. The reading should be: $R > 10 M\Omega$. <i>Connecter les circuits A, B, D et E à la masse. Utiliser un Megger sur la position 500 V, mesurer la résistance d'isolement entre le circuit C et la masse. La valeur mesurée doit être : $R > 10 M\Omega$.</i></p> | 75.1GΩ | PASSED |
| <p>Test with an AC voltage of 1.5 kVrms (50Hz) between circuit C and the ground for 1 minute. The test is considered to be satisfactory if no discharge flash or spark is observed. <i>Tester à une tension de 1,5KVrms (50Hz) entre le circuit C et la masse pendant une minute. Le test est considéré comme satisfaisant si aucun flash ou perçement n'est observé.</i></p> | 4.9mA | PASSED |
| <p>Repeat the measurement with the MEGGER set to 500V. The resistance between circuit C and the ground. The reading must not vary by more than 10% from the previously measured value. If the reading is higher, investigate and rectify <i>Répéter la mesure au Megger sur la position 500V du circuit C par rapport à la masse. La résistance mesurée ne doit varier de plus de 10% de la mesure préliminaire. Si cette mesure est supérieure, investiguer et réparer le défaut.</i></p> | 6.00GΩ | PASSED |

| | | | | |
|---|--|--|--|--|
|  | <p align="center">Page 15 of 46</p> | <p align="center">CODE DTR0000970658</p> | <p align="center">FINAL TEST CERTIFICATE AU_CVS 437</p> | <p align="center">DTR0100034034 Rev: C</p> |
|---|--|--|--|--|

Group D (<36V LV and networks cables) / Groupe D (TBT <36Vdc et réseau)

| | Measure <i>Mesure</i> | Passed / Failed <i>Correct et OK</i> |
|--|--------------------------|---|
| <p>Connect circuit A, B, C and E to the ground, Using a MEGGER set to 500V, measure the resistance between circuit D and the ground. The reading should be: $R > 10 \text{ M}\Omega$. <i>Connecter les circuits A, B, C et E à la masse. Utiliser un Megger sur la position 500 V, mesurer la résistance d'isolement entre le circuit D et la masse. La valeur mesurée doit être : $R > 10 \text{ M}\Omega$.</i></p> | 69.9GΩ | PASSED |
| <p>Test with an AC voltage of 500 Vrms (50Hz) between circuit D and the ground for 1 minute. The test is considered to be satisfactory if no discharge flash or spark is observed. <i>Tester à une tension de 0,5KVrms (50Hz) entre le circuit D et la masse pendant une minute. Le test est considéré comme satisfaisant si aucun flash ou percement n'est observé.</i></p> | 3.7mA | PASSED |
| <p>Repeat the measurement with the MEGGER set to 500V. The resistance between circuit D and the ground. The reading must not vary by more than 10% from the previously measured value. If the reading is higher, investigate and rectify <i>Répéter la mesure au Megger sur la position 500V du circuit D par rapport à la masse. La résistance mesurée ne doit varier de plus de 10% de la mesure préliminaire. Si cette mesure est supérieure, investiguer et réparer le défaut.</i></p> | 8.00GΩ | PASSED |

Group E (loop fire) / Groupe E (circuit incendie)

| | Measure <i>Mesure</i> | Passed / Failed <i>Correct et OK</i> |
|--|--------------------------|---|
| <p>Connect circuit A, B, C and D to the ground, Using a MEGGER set to 500V, measure the resistance between circuit E and the ground. The reading should be: $R > 10 \text{ M}\Omega$. <i>Connecter les circuits A, B, C et D à la masse. Utiliser un Megger sur la position 500 V, mesurer la résistance d'isolement entre le circuit E et la masse. La valeur mesurée doit être : $R > 10 \text{ M}\Omega$.</i></p> | 11.0GΩ | PASSED |
| <p>Test with an AC voltage of 500 Vrms (50Hz) between circuit E and the ground for 1 minute. The test is considered to be satisfactory if no discharge flash or spark is observed. <i>Tester à une tension de 0,5KVrms (50Hz) entre le circuit E et la masse pendant une minute. Le test est considéré comme satisfaisant si aucun flash ou percement n'est observé.</i></p> | 0.2mA | PASSED |
| <p>Repeat the measurement with the MEGGER set to 500V. The resistance between circuit E and the ground. The reading must not vary by more than 10% from the previously measured value. If the reading is higher, investigate and rectify <i>Répéter la mesure au Megger sur la position 500V du circuit E par rapport à la masse. La résistance mesurée ne doit varier de plus de 10% de la mesure préliminaire. Si cette mesure est supérieure, investiguer et réparer le défaut.</i></p> | 19.5GΩ | PASSED |
| <p>Disconnect the rectifier on X101_FD. Using a MEGGER set to 100V, measure the resistance between terminal 18XR11_1 / 40 and terminal 18XR11_1 / 41. The reading should be: $R > 10 \text{ M}\Omega$. <i>Déconnecter la diode sur X101_FD. Utiliser un Megger sur la position 100Vdc, mesurer la résistance d'isolement entre les bornes 18XR11_1 / 40 et 18XR11_1 / 41. La mesure doit être : $R > 10 \text{ M}\Omega$.</i></p> | - | PASSED |

Remark/ Remarque:

Remove all dielectric test connectors and the short circuits.

| | | | | |
|---|--|--|--|--|
|  | <p align="center">Page 16 of 46</p> | <p align="center">CODE DTR0000970658</p> | <p align="center">FINAL TEST CERTIFICATE AU_CVS 437</p> | <p align="center">DTR0100034034 Rev: C</p> |
|---|--|--|--|--|

Do not reconnect the capacitors and the resistors, they have to be check after.

*Enlever tous les connecteurs de tests et les court-circuits installés.
Ne pas câbler les condensateurs et les résistances car ceux-ci vont être mesurés.*

5.8 Verify the value of the resistors / Vérification de la valeur des résistances.

Measure the value of the resistors and verify the conformity with the board below:

Mesurer la valeur des résistances et vérifier la conformité avec les valeurs reprises dans le tableau ci-dessous:

| Item's <i>Appareil</i> | Nominal value <i>Valeur nominale</i> | Criteria <i>Critère</i> | Measure <i>Mesure</i> | Passed / Failed <i>(OK / NOK)</i> |
|---------------------------|---|---|----------------------------------|--------------------------------------|
| R1 | 200 K Ω | 190 K Ω < value < 210 K Ω | 202.8kΩ | PASSED |
| R2 | 200 K Ω | 190 K Ω < value < 210 K Ω | 202.0kΩ | PASSED |
| R(HF)ENT-CVS | 1 Ω | 0.95 Ω < value < 1.05 Ω | 1.02Ω | PASSED |
| R1(IOFC) terminals 1-2 | 280 K Ω | 252 K Ω < value <308 K Ω | 284.6kΩ | PASSED |
| R1(IOFC) terminals 3-4 | 280 K Ω | 252 K Ω < value <308 K Ω | 284.4kΩ | PASSED |
| R2(IOFC) terminals 1-2 | 280 K Ω | 252 K Ω < value <308 K Ω | 286.5kΩ | PASSED |
| R3 terminals 1-2 | 1 M Ω | 0.9 M Ω < value < 1.1 M Ω | 0.946MΩ | PASSED |
| R3' terminals 3-4 | 1 M Ω | 0.9 M Ω < value < 1.1 M Ω | 0.939MΩ | PASSED |
| R4 terminals 1-2 | 1 M Ω | 0.9 M Ω < value < 1.1 M Ω | 0.956MΩ | PASSED |
| R4' terminals 3-4 | 1 M Ω | 0.9 M Ω < value < 1.1 M Ω | 0.960MΩ | PASSED |
| R5 terminals 1-2 | 1 M Ω | 0.9 M Ω < value < 1.1 M Ω | 0.954MΩ | PASSED |
| R5' terminals 3-4 | 1 M Ω | 0.9 M Ω < value < 1.1 M Ω | 0.937MΩ | PASSED |
| R6 terminals 1-2 | 1 M Ω | 0.9 M Ω < value < 1.1 M Ω | 0.915MΩ | PASSED |
| R6' terminals 3-4 | 1 M Ω | 0.9 M Ω < value < 1.1 M Ω | 0.962MΩ | PASSED |
| CCZ | 270 Ω | 256.5 Ω < value < 283.5 Ω | 266.9Ω | PASSED |
| CCZ2-R | 5.6 Ω | 5.32 Ω < value < 5.88 Ω | 5.6Ω | PASSED |
| CCZ2-S | 5.6 Ω | 5.32 Ω < value < 5.88 Ω | 5.6Ω | PASSED |
| CCZ2-T | 5.6 Ω | 5.32 Ω < value < 5.88 Ω | 5.6Ω | PASSED |
| IOCMD-L1 (S1-S2) | 1.1 Ω | 0.7 Ω < value < 1.5 Ω | 1.0Ω | PASSED |
| IOCMD-L2 (S1-S2) | 1.1 Ω | 0.7 Ω < value < 1.5 Ω | 1.0Ω | PASSED |
| IOCMD-L3 (S1-S2) | 1.1 Ω | 0.7 Ω < value < 1.5 Ω | 1.0Ω | PASSED |

| | | | | |
|---|---------------|-------------------------------------|--|---|
|  | Page 17 of 46 | CODE DTR0000970658 | FINAL TEST CERTIFICATE AU_CVS 437 | DTR0100034034 Rev: C |
|---|---------------|-------------------------------------|--|---|

| | | | | |
|--|-------|-----------------------|------|--------|
| AOCMD-L1 (S1-S2) | 4.7 Ω | 2.9 Ω < value < 6.5 Ω | 4.6Ω | PASSED |
| AOCMD-L2 (S1-S2) | 4.7 Ω | 2.9 Ω < value < 6.5 Ω | 3.7Ω | PASSED |
| AOCMD-L3 (S1-S2) | 4.7 Ω | 2.9 Ω < value < 6.5 Ω | 4.6Ω | PASSED |
| Cleaned up of the converter after measures, cabling resistors and capacitors | | | | DONE |

| DEPARTMENT <i>Département</i> | NAME (S) <i>Nom(s)</i> | Function <i>Fonction</i> | DATE <i>Date</i> | RESULTS |
|-------------------------------|--------------------------------|--------------------------|-------------------|---------|
| ALSTOM UBUNYE TRACTION | LUCKY KGWADI THABO SISHANGE | DIELECTRIC TEST | 09/07/2024 | PASSED |

5.9 Circuit breaker check / Vérification des disjoncteurs

| Item <i>Appareil</i> | Trip current (A) <i>Valeur de la protection</i> | Observed values <i>Valeur relevée</i> | Passed / Failed (OK / NOK) |
|----------------------|---|---------------------------------------|----------------------------|
| FANP | 6 A | 6A | PASSED |
| CC(AL)ACU | 3 A | 3A | PASSED |
| CC(ALS) | 5 A | 5A | PASSED |

5.10 Fuses check / Vérification des fusibles

| Item <i>Appareil</i> | Theoretical values <i>Valeur théorique</i> | Observed values <i>Valeur relevée</i> | Passed / Failed (OK / NOK) |
|-------------------------------|--|---------------------------------------|----------------------------|
| BCOF | 315 A / 690V | 315 A / 690 V | PASSED |
| SHSF (3 fuses / 3 fusibles) | 2 A / 500V | 2 A / 500 V | PASSED |

5.11 Relay PHR setup / Réglages du PHR.

| PHR setting / <i>Réglages du PHR</i> | Passed / Failed (OK / NOK) |
|---|----------------------------|
| Adjust the PHR relay according to procedure below / <i>Ajuster les différents réglages du PHR comme suit:</i> | DONE |

| | | | | |
|---|--|--|---|--|
|  | <p align="center">Page 18 of 46</p> | <p align="center">CODE DTR0000970658</p> | <p align="center">FINAL TEST CERTIFICATE AU_CVS 437</p> | <p align="center">DTR0100034034 Rev: C</p> |
|---|--|--|---|--|

Two different versions of the phase detection device may be installed.

Deux modèles de détection de phase peuvent être installés.

The picture shows both PHR models with the correct setting.

Les figures montrent les réglages corrects à effectuer.

- Umax (>U): 460 V
- Umin (<U) : 340V
- Phase unbalance threshold (Asym): 15%
- Delay (T): 0 second
- Switch on delay
- Red switch placed downwards on the left model. *Bouton rouge du modèle de gauche doit être dirigé vers le bas.*
- Both switches placed downwards (OFF state) on right model. *Les deux boutons sur le modèle de droite doivent être dirigés vers le bas*



5.12 Off power tests / Tests à blanc

6 Checking power of transducers / Vérification alimentation des transducteurs

Modules inverter and battery charger are not mounted in a case

Les modules onduleurs et chargeur batterie ne sont pas montés dans le coffre.

- Jump with a wire **BAR-BAT+** (HB050A) and **BAR-DC+PREP** (HB052A)
Ponter avec un fil les points BAR-BAT+ (HB050A) and BAR-DC+PREP (HB052A)
- Switch ON the **Battery presence** on the test bench and switch ON **Battery contactor closing** on the manual test tool.

Activer la tension batterie sur le banc de test et démarrer le CVS en basse tension en activant le switch "Battery contactor closing" de la boîte manuelle.

| Measuring device <i>Appareil à mesurer</i> | Caliber <i>Calibre transducteur</i> | Terminal <i>Bornes</i> | Supply voltage <i>Tension alimentation</i> | Measure <i>Mesure</i> | Passed / Failed <i>(OK / NOK)</i> |
|---|--|---------------------------|---|--------------------------|--------------------------------------|
| LVMD | LV 100 - 4000 / SP6 4000V / 50mA | + - | +15 V ± 1 V -15 V ± 1 V | +14.99 V -15.17 V | PASSED |

| | | | | |
|---|----------------------|-------------------------------------|--|---|
|  | Page 19 of 46 | CODE DTR0000970658 | FINAL TEST CERTIFICATE AU_CVS 437 | DTR0100034034 Rev: C |
|---|----------------------|-------------------------------------|--|---|

| | | | | | |
|--------------|------------------------------|----------------------------|----------------------------|------------------------|--------|
| AOVMD1 | LV 25-600/SP1 600V / 25mA | + - | +15 V ± 1 V -15 V ± 1 V | + 14.99 V - 15.17 V | PASSED |
| AOVMD2 | LV 25-600/SP1 600V / 25mA | + - | +15 V ± 1 V -15 V ± 1 V | + 14.99 V -15.17 V | PASSED |
| CA(DB-VT)CVS | TURCK FCS-M18-LIX | XS-FA-CVS/1 XS-FA-CVS/3 | +24 V ± 2 V | + 24.01 V | PASSED |

7 Programming control unit / Programmation de l'électronique de contrôle.

Program the control unit (Agate) with the revision software released in the Configuration Follow up document.
Programmer l'électronique de contrôle (Agate) avec la révision du software correspondant au document de configuration CVS

7.1.1.1 Procedure of programming of electronics / Procédure de programmation du software.

Without establishing dialogue (MMAP) / *Sans établir le dialogue (MMAP)*

- Open the software **Flash32** on the desktop, open the file corresponding to the software you need to upload "**PRASA_V3.1.3\PRASA_3KV_XXXX.s3**", and check the following settings.
Préparer flash32 avec tous les paramètres courants ainsi que le fichier à télécharger.

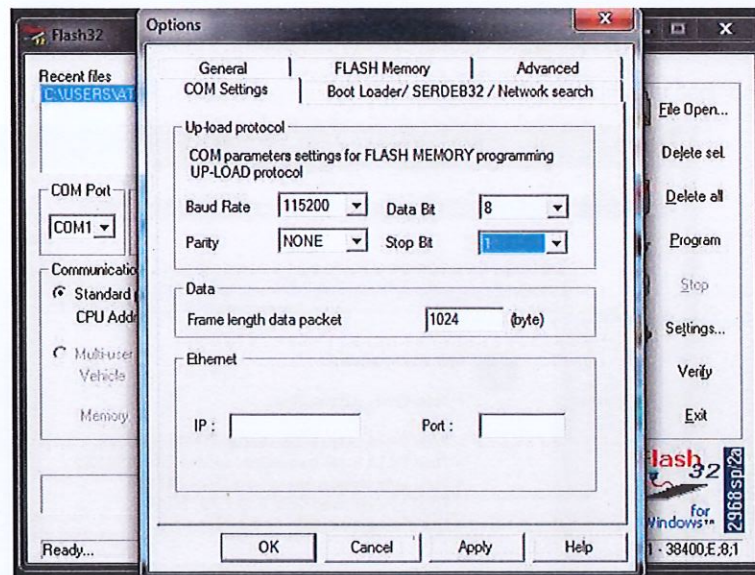

- Now, switch on the follow switches on the control desk :
Mettre sous tension l'électronique et demander la programmation dans les 10 sec
 - **Battery Presence** (battery simulator control remote)
 - **Battery ON** (control desk)
 - **Manual Box ON** (control desk)

| | | | | |
|---|--|--|--|--|
|  | <p align="center">Page 20 of 46</p> | <p align="center">CODE DTR0000970658</p> | <p align="center">FINAL TEST CERTIFICATE AU_CVS 437</p> | <p align="center">DTR0100034034 Rev: C</p> |
|---|--|--|--|--|

- As soon as you will push the next switch, you will have a window of 10 seconds to click on **Program** to launch the upload of the software.
 - **Battery contactor closing** (Manual Box)
- After the upload started, you must see the load bar charging:

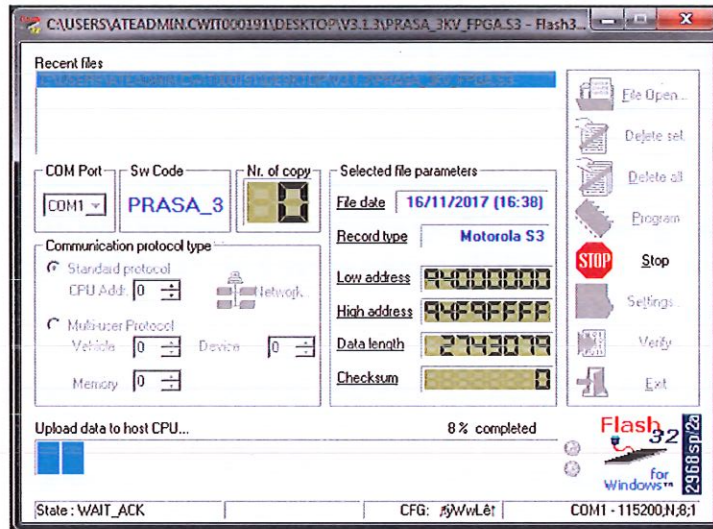

- If the connection or the upload fails, restart this procedure.
- Once the upload is complete, you must read the following message:

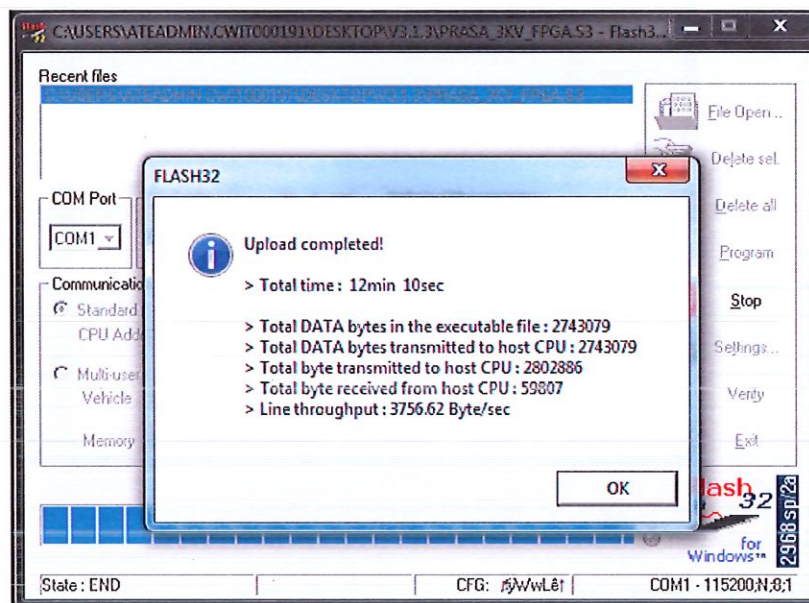

- After the upload, restart the control electronic by switching ON and OFF the battery presence./ Après programmation, redémarrer l'électronique

| | | | | |
|---|----------------------|-------------------------------------|--|---|
|  | Page 21 of 46 | CODE DTR0000970658 | FINAL TEST CERTIFICATE AU_CVS 437 | DTR0100034034 Rev: C |
|---|----------------------|-------------------------------------|--|---|

| | File number installed / software revision <i>Nom du fichier installé / version software</i> | Passed / Failed (OK / NOK) |
|---|--|-------------------------------|
| Software control unit and file name (extension .a3s) <i>Software électronique de contrôle et nom de fichier (extension .a3s)</i> | 7b9f3723.a3s | OK |

8 Checking of logical inputs and outputs / Vérification des entrées et sorties logiques

At the stage, please add the STPI relays (K1 to K7) in the CVS

Placer les relais STPI (K1 à K7) dans le CVS

| | Insert the K6 Relay code | Passed / Failed (OK / NOK) |
|--|--------------------------|-------------------------------|
| Ensure that the correct Relay is fitted on K6 Code THLAO YXY | YXY | OK |

After starting the CVS with the battery voltage, open the communication with **MMAP**:

- Turn ON the **IES STATUS** on the test bench
Placer l'interrupteur "IES STATUS" => 1 sur le banc de test

Click on the shortcut MMAP on the desktop

- Click on **Equipment, Open**, then select the file **AAUX3S.eqp**
- Click on **Equipment, and Open dialogue**.

Once the dialog established, open the test interface by clicking on File, Open, then select the file "**Contactors_test.tdb**".

- Click on pair of spectacles (1) to activate the variables readings and click to icone HTML(2)
Cliquer sur la paire de lunette (1) pour activer la lecture des variables et cliquer sur l'icône HTML (2)

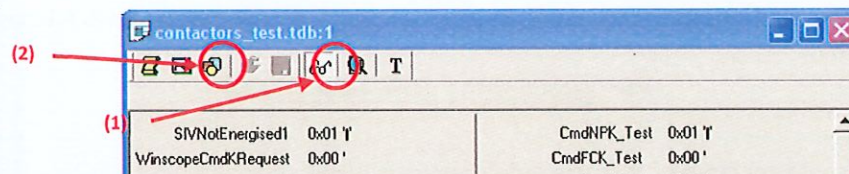

- Verify that **Condition to start** is colored in green
Vérifier que « Condition to start » est coloré en vert.

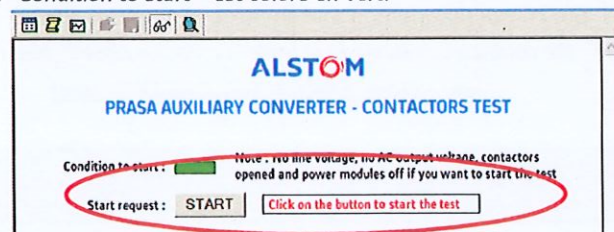

- Click on **START** to start the test, and check the contactors with the following procedure.
Cliquer sur le bouton start pour démarrer le test, vérifier que chaque sorties correspondent à la figure ci-après.

| | | | | |
|---|----------------------|-------------------------------------|--|---|
|  RESTRICTED ALSTOM UBUNYE | Page 22 of 46 | CODE DTR0000970658 | FINAL TEST CERTIFICATE AU_CVS 437 | DTR0100034034 Rev: C |
|---|----------------------|-------------------------------------|--|---|

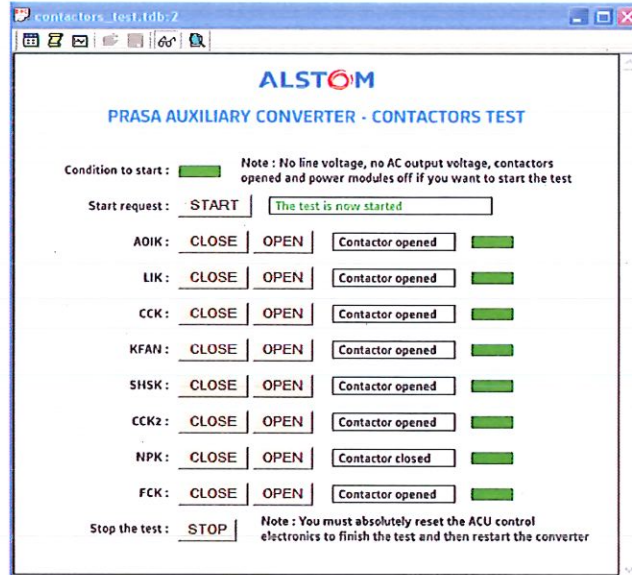

Procedure and explanation for the contactors test / *Procédure et explication pour le test des contacteurs*

For test an output contactor opened / *Pour une sortie contacteur ouvert*

AOIK:

Click on the button **CLOSE**, the contactor closing and the text "Contactor opened" go to "Contactor closed".
Cliquer sur le bouton "CLOSE", the contacteur se ferme et le texte "Contactor opened" passe en "Contactor closed"

The green lamp temporarily switches to red and then stays green (If the lamp is green then the command of contactor is equal that status of contactor)

Le voyant vert passe un court instant en rouge avant de se figer en vert (Si le voyant est vert alors la commande est égale au status du contacteur).

AOIK:

For test an output contactor closed / *Pour une sortie contacteur fermé.*















NPK:

Click on the button **OPEN**, the contactor opening and the text "Contactor closed" go to "Contactor opened".
Cliquer sur le bouton "OPEN", the contacteur s'ouvre et le texte "Contactor closed" passe en "Contactor opened"

NPK:

| Action <i>Action</i> | Result <i>résultat</i> | Passed / Failed (OK / NOK) |
|---|---|-------------------------------|
| Click on button « CLOSE » AOIK <i>Cliquer sur le bouton "CLOSE" AOIK</i> | AOIK: <input type="button" value="CLOSE"/> <input type="button" value="OPEN"/> <input type="button" value="Contactor closed"/> <input type="checkbox"/> | PASSED |
| Click on button « OPEN » AOIK <i>Cliquer sur le bouton "OPEN" AOIK</i> | AOIK: <input type="button" value="CLOSE"/> <input type="button" value="OPEN"/> <input type="button" value="Contactor opened"/> <input type="checkbox"/> | PASSED |

| | | | | |
|---|---------------|-------------------------------------|--|---------------------------------------|
|  | Page 23 of 46 | CODE DTR0000970658 | FINAL TEST CERTIFICATE AU_CVS 437 | DTR0100034034 Rev: C |
|---|---------------|-------------------------------------|--|---------------------------------------|

| Action <i>Action</i> | Result <i>résultat</i> | Passed / Failed <i>(OK / NOK)</i> |
|--|--|--------------------------------------|
| Click on button « CLOSE » LIK <i>Cliquer sur le bouton "CLOSE" LIK</i> | LIK: <input type="button" value="CLOSE"/> <input type="button" value="OPEN"/> <input type="button" value="Contactor closed"/>  | PASSED |
| Click on button « OPEN » LIK <i>Cliquer sur le bouton "OPEN" LIK</i> | LIK: <input type="button" value="CLOSE"/> <input type="button" value="OPEN"/> <input type="button" value="Contactor opened"/>  | PASSED |
| Click on button « CLOSE » CCK <i>Cliquer sur le bouton "CLOSE" CCK</i> | CCK: <input type="button" value="CLOSE"/> <input type="button" value="OPEN"/> <input type="button" value="Contactor closed"/>  | PASSED |
| Click on button « OPEN » CCK <i>Cliquer sur le bouton "OPEN" CCK</i> | CCK: <input type="button" value="CLOSE"/> <input type="button" value="OPEN"/> <input type="button" value="Contactor opened"/>  | PASSED |
| Click on button « CLOSE » KFAN <i>Cliquer sur le bouton "CLOSE" KFAN</i> | KFAN: <input type="button" value="CLOSE"/> <input type="button" value="OPEN"/> <input type="button" value="Contactor closed"/>  | PASSED |
| Click on button « OPEN » KFAN <i>Cliquer sur le bouton "OPEN" KFAN</i> | KFAN: <input type="button" value="CLOSE"/> <input type="button" value="OPEN"/> <input type="button" value="Contactor opened"/>  | PASSED |
| Click on button « CLOSE » SHSK (LIK and CCK are opened for this output) <i>Cliquer sur le bouton "CLOSE" SHSK (LIK et CCK sont ouvert pour cette sortie)</i> | SHSK: <input type="button" value="CLOSE"/> <input type="button" value="OPEN"/> <input type="button" value="Contactor closed"/>  | PASSED |
| Click on button « OPEN » SHSK <i>Cliquer sur le bouton "OPEN" SHSK</i> | SHSK: <input type="button" value="CLOSE"/> <input type="button" value="OPEN"/> <input type="button" value="Contactor opened"/>  | PASSED |
| Click on button « CLOSE » CCK2 <i>Cliquer sur le bouton "CLOSE" CCK2</i> | CCK2: <input type="button" value="CLOSE"/> <input type="button" value="OPEN"/> <input type="button" value="Contactor closed"/>  | PASSED |
| Click on button « OPEN » CCK2 <i>Cliquer sur le bouton "OPEN" CCK2</i> | CCK2: <input type="button" value="CLOSE"/> <input type="button" value="OPEN"/> <input type="button" value="Contactor opened"/>  | PASSED |
| Click on button « OPEN » NPK <i>Cliquer sur le bouton "OPEN" NPK</i> | NPK: <input type="button" value="CLOSE"/> <input type="button" value="OPEN"/> <input type="button" value="Contactor opened"/>  | PASSED |
| Click on button « CLOSE » NPK <i>Cliquer sur le bouton "CLOSE" NPK</i> | NPK: <input type="button" value="CLOSE"/> <input type="button" value="OPEN"/> <input type="button" value="Contactor closed"/>  | PASSED |
| Click on button « CLOSE » FCK <i>Cliquer sur le bouton "CLOSE" FCK</i> | FCK: <input type="button" value="CLOSE"/> <input type="button" value="OPEN"/> <input type="button" value="Contactor closed"/>  | PASSED |
| Click on button « OPEN » FCK <i>Cliquer sur le bouton "OPEN" FCK</i> | FCK: <input type="button" value="CLOSE"/> <input type="button" value="OPEN"/> <input type="button" value="Contactor opened"/>  | PASSED |
| Click to button "STOP" Cliquer sur le bouton "STOP" | Stop the test: <input type="button" value="STOP"/> Note : You must absolutely reset the ACU control electronics to finish the test and then restart the converter | |

- Open "Contactors_test.tdb" and "IO Checks.tdb" files
Ouvrir les fichiers "Contactors_test.tdb" et I_0.tdb
- Click on pair of spectacles to activate the variables readings
Cliquer sur la paire de lunette pour activer la lecture des variables

| Logical inputs in manual mode / <i>Vérification des entrées logiques en mode manuel.</i> | | |
|--|---|--------------------------------------|
| MMAP variable <i>Variable MMAP</i> | Procedure <i>Procédure</i> | Passed / Failed <i>(OK / NOK)</i> |
| LI_StatusFanP (INO) | Open the FANP thermal protection / <i>Ouvrir la protection thermique FANP</i> Check that the variable goes to 0 / <i>Vérifier que la variable passe à 0.</i> | PASSED |

| | | | | |
|---|----------------------|-------------------------------------|--|---|
|  RESTRICTED ALSTOM UBUNYE | Page 24 of 46 | CODE DTR0000970658 | FINAL TEST CERTIFICATE AU_CVS 437 | DTR0100034034 Rev: C |
|---|----------------------|-------------------------------------|--|---|

| | | |
|----------------------|---|--------|
| LI_StatusPHR (IN6) | Short circuit the terminal PHR / 15 with PHR / 18 / <i>Court-circuiter les bornes PHR / 15 avec PHR / 18</i> Check that the variable goes to 1 / <i>Vérifier que la variable passe à 1.</i> | PASSED |
| LI_BackUp (IN8) | Close "BACK_UP MODE" switch on the test bench. / <i>Basculer à 1 l'interrupteur "BACK_UP MODE"</i> Check that the variable goes to 1 / <i>Vérifier que la variable passe à 1.</i> | PASSED |
| LI_ByPass (IN9) | Close "CVS BY_PASS" switch on the test bench. / <i>Basculer à 1 l'interrupteur "CVS BY_PASS"</i> Check that the variable goes to 1 / <i>Vérifier que la variable passe à 1.</i> | PASSED |
| LI_TC2 (IN10) | Close "AuxCode2" switch on the test bench. / <i>Basculer à 1 l'interrupteur "AuxCode2"</i> Check that the variable goes to 1 / <i>Vérifier que la variable passe à 1.</i> | PASSED |
| LI_TC1 (IN11) | Close "AuxCode1" switch on the test bench. / <i>Basculer à 1 l'interrupteur "AuxCod1"</i> Check that the variable goes to 1 / <i>Vérifier que la variable passe à 1.</i> | PASSED |
| LI_StatusHSCB (IN13) | Close "Start_CVS" switch on the test bench. / <i>Basculer à 1 l'interrupteur "Start_CVS"</i> Force also the relay R4 on the test bench / <i>Forcer le relais R4 du banc de test.</i> Check that the variable goes to 1 / <i>Vérifier que la variable passe à 1.</i> | PASSED |
| LI_StatusBCOF (IN14) | Force BCOF contact of Fuse. / <i>Basculer le contact du fusible BCOF en position ouvert</i> Check that the variable goes to 0 / <i>Vérifier que la variable passe à 0.</i> | PASSED |

| Relay BCOK / Relais BCOK | | | |
|---------------------------------|---|---|---------------------------------------|
| Relay Relais | Action Action | Result Résultat | Passed / Failed (OK / NOK) |
| BCOK | On the test bench, push the button "Battery contactor closing" <i>Pousser sur le bouton poussoir du banc de test nommé "Battery contactor closing"</i> | The relay BCOK => 1 and on the test bench the LIGHT Battery closing is ON <i>Le relais BCOK => 1 et la signalisation "Battery closing" s'illumine (le banc de test)</i> | PASSED |

9 IGBT pulses test / Vérification des impulsions IGBT

Use **MMAP** software to force variable and check inputs.

Utiliser le logiciel MMAP pour forcer les variables et vérifier les retours.

- Open **igbt_test.tdb** file
Ouvrir le tableau de bord "igbt_test.tdb"
- Click on the pair of spectacles (1) to activate the variables readings and click to icone HTML(2)
Cliquer sur la paire de lunettes (1) pour activer la lecture des variables et cliquer sur l'icone HTML (2)

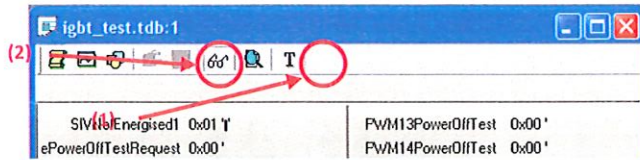

- Verify that **Condition to start** is colored in green
Vérifier que « Condition to start » est coloré en vert.

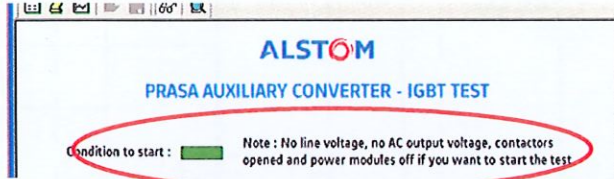

- Click to button **START** for start the test, verify each output is equal with the figure below
Cliquer sur le bouton start pour démarrer le test, vérifier que chaque sorties correspondent à la figure ci-après.

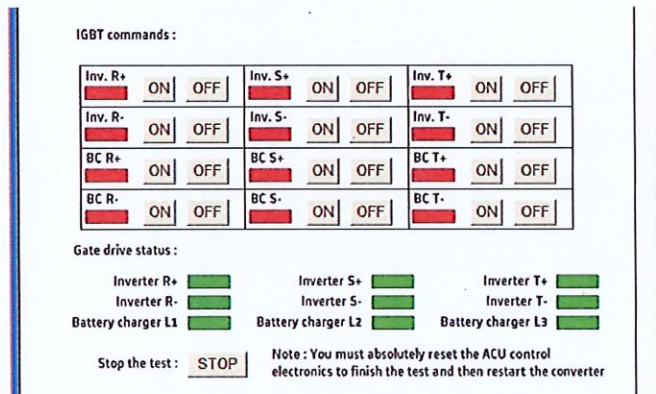

- The module is supplied by 2 external power supplies of 24 Vdc in serie on the + and – bars of the module. At each step, the output voltage is measured between **O** and **R**, **S** and **T** of the module.
A chaque étape, mesurer et vérifier à l'aide d'un multimètre, la tension entre les points O et les barres R, S et T).

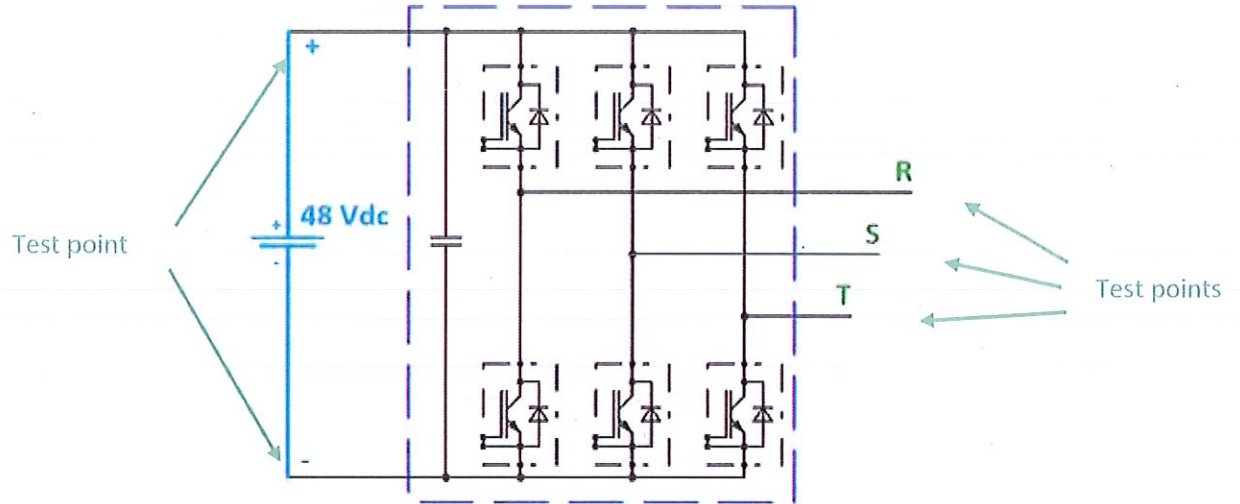

Results :

| Battery charger module / Module chargeur de batterie | | | | | |
|---|--------|--|------------------------------------|-----------------------------------|---|
| | | Theoretical value <i>Valeurs théorique</i> | Criteria <i>Critères</i> | Measures <i>Mesures</i> | Passed / Failed (OK / NOK) |
| Click to button "ON" BC. R+ <i>Cliquer sur le bouton "ON" BC. R+</i> | | | | | |
| Output voltage on R | R+ ON | + 48 V | ±2V | 48.46 V | PASSED |
| | R+ OFF | + 9 V | ±2V | 9.36 V | PASSED |
| Click to button "OFF" BC. R+ <i>Cliquer sur le bouton "OFF" BC. R+</i> | | | | | |
| Click to button "ON" BC. R- <i>Cliquer sur le bouton "ON" BC. R-</i> | | | | | |
| Output voltage on R | R- ON | 0 V | ±2V | 0.428 V | PASSED |
| | R- OFF | +9 V | ±2V | 9.37 V | PASSED |
| Click to button "OFF" BC. R- <i>Cliquer sur le bouton "OFF" BC. R-</i> | | | | | |
| Click to button "ON" BC. S+ <i>Cliquer sur le bouton "ON" BC. S+</i> | | | | | |
| Output voltage on S | S+ ON | + 48 V | ±2V | 48.47 V | PASSED |
| | S+ OFF | +9 V | ±2V | 9.39 V | PASSED |
| Click to button "OFF" BC. S+ <i>Cliquer sur le bouton "OFF" BC. S+</i> | | | | | |
| Click to button "ON" BC. S- <i>Cliquer sur le bouton "ON" BC. S-</i> | | | | | |
| Output voltage on S | S- ON | 0 V | ±2V | 0.429 V | PASSED |
| | S- OFF | +9 V | ±2V | 9.40 V | PASSED |
| Click to button "OFF" BC. S- <i>Cliquer sur le bouton "OFF" BC. S-</i> | | | | | |
| Click to button "ON" BC. T+ <i>Cliquer sur le bouton "ON" BC. T+</i> | | | | | |
| Output voltage on T | T+ ON | + 48 V | ±2V | 48.47 V | PASSED |
| | T+ OFF | +9 V | ±2V | 9.39 V | PASSED |
| Click to button "OFF" BC. T+ <i>Cliquer sur le bouton "OFF" BC. T+</i> | | | | | |
| Click to button "ON" BC. T- <i>Cliquer sur le bouton "ON" BC. T-</i> | | | | | |
| Output voltage on T | T- ON | 0 V | ±2V | 0.430 V | PASSED |
| | T- OFF | +9 V | ±2V | 9.39 V | PASSED |
| Click to button "OFF" BC. T- <i>Cliquer sur le bouton "OFF" BC. T-</i> | | | | | |

| | | | | |
|---|----------------------|-------------------------------------|---|---------------------------------------|
|  RESTRICTED ALSTOM UBUNYE | Page 28 of 46 | CODE DTR0000970658 | FINAL TEST CERTIFICATE AU_CVS 437 | DTR0100034034 Rev: C |
|---|----------------------|-------------------------------------|---|---------------------------------------|

Click to button "STOP"
Cliquer sur le bouton "STOP"

Stop the test : **STOP**

Note : You must absolutely reset the ACU control electronics to finish the test and then restart the converter .

While the module is supplied, check the following voltages of the transducers of the battery charger module:
 Verifier les niveaux de tension suivants sur les transducteurs du module chargeur batterie.

| Measuring device <i>Appareil à mesurer</i> | Caliber <i>Calibre transducteur</i> | Terminal <i>Bornes</i> | Supply voltage <i>Tension alimentation</i> | Measure <i>Mesure</i> | Passed / Failed <i>(OK / NOK)</i> |
|---|--|---------------------------|---|--------------------------|--------------------------------------|
| IBCM-R | LTC 350-T 350A 1/2000 | XBCM1/A | +15 V ± 1 V | + 15.02 V | PASSED |
| | | XBCM1/B | -15 V ± 1 V | - 15.57 V | |
| IBCM-S | LTC 350-T 350A 1/2000 | XBCM1/M | +15 V ± 1 V | + 15.02 V | PASSED |
| | | XBCM1/N | -15 V ± 1 V | - 15.57 V | |
| IBAT | LTC 350-T 350A 1/2000 | XBCM1/K | +15 V ± 1 V | +15.02 V | PASSED |
| | | XBCM1/T | -15 V ± 1 V | - 15.57 V | |

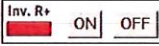
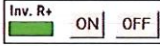
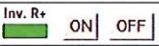
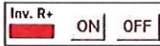
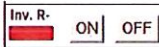
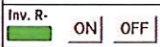
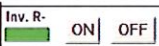
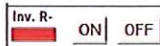
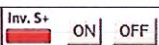
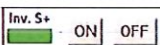
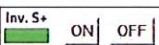
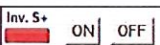
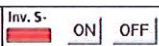
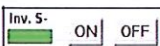
| Inverter module / Module onduleur | | | | |
|---|---|--|---|--------------------------------------|
| | Theoretical value <i>Valeurs théorique (V)</i> | Criteria <i>Critères (V)</i> | Measures <i>Mesures (V)</i> | Passed / Failed <i>(OK / NOK)</i> |
| Click to button "ON" INV. R+ <i>Cliquer sur le bouton "ON" INV. R+</i> | |  |  | |
| Output voltage on R | + 48 V | ±2V | 48.88 V | PASSED |
| | +15 V | ±2V | 15.58 V | PASSED |
| Click to button "OFF" INV. R+ <i>Cliquer sur le bouton "OFF" INV. R+</i> | |  |  | |
| Click to button "ON" INV. R- <i>Cliquer sur le bouton "ON" INV. R-</i> | |  |  | |
| Output voltage on R | 0 V | ±2V | 0.030 V | PASSED |
| | + 15 V | ±2V | 15.58 V | PASSED |
| Click to button "OFF" INV. R- <i>Cliquer sur le bouton "OFF" INV. R-</i> | |  |  | |
| Click to button "ON" INV. S+ <i>Cliquer sur le bouton "ON" INV. S+</i> | |  |  | |
| Output voltage on S | + 48 V | ±2V | 48.90 V | PASSED |
| | + 15 V | ±2V | 15.58 V | PASSED |
| Click to button "OFF" INV. S+ <i>Cliquer sur le bouton "OFF" INV. S+</i> | |  |  | |
| Click to button "ON" INV. S- <i>Cliquer sur le bouton "ON" INV. S-</i> | |  |  | |

Inverter module / Module onduleur

| | Theoretical value <i>Valeurs théorique</i> (V) | Criteria <i>Critères</i> (V) | Measures <i>Mesures</i> (V) | Passed / Failed (OK / NOK) |
|---|--|------------------------------------|-----------------------------------|-------------------------------|
| Click to button "ON" INV. R+ <i>Cliquer sur le bouton "ON" INV. R+</i> | | | | |
| Output voltage on S | 0 V | ±2V | 0.020 V | PASSED |
| | + 15 V | ±2V | 15.57 V | PASSED |
| Click to button "OFF" INV. S- <i>Cliquer sur le bouton "OFF" INV. S-</i> | | | | |
| Click to button "ON" INV. T+ <i>Cliquer sur le bouton "ON" INV. T+</i> | | | | |
| Output voltage on T | + 48 V | ±2V | 48.90 V | PASSED |
| | + 15 V | ±2V | 15.59 V | PASSED |
| Click to button "OFF" INV. T+ <i>Cliquer sur le bouton "OFF" INV. T+</i> | | | | |
| Click to button "ON" INV. T- <i>Cliquer sur le bouton "ON" INV. T-</i> | | | | |
| Output voltage on T | 0 V | ±2V | 0.011 V | PASSED |
| | + 15 V | ±2V | 15.58 V | PASSED |
| Click to button "OFF" INV. T- <i>Cliquer sur le bouton "OFF" INV. T-</i> | | | | |

| | | | | |
|---|----------------------|-------------------------------------|--|---|
|  | Page 30 of 46 | CODE DTR0000970658 | FINAL TEST CERTIFICATE AU_CVS 437 | DTR0100034034 Rev: C |
|---|----------------------|-------------------------------------|--|---|

10 IES test only with software > V3.0.0/ Test IES seulement avec software > V3.0.0

Test

Passed / Correct
(OK / NOK)

Check that the Power supply CM-AL-110/15-CVS goes off when switching OFF the IES status on the test box.

Vérifier que l'alimentation CM-AL-110/15-CVS s'éteint lorsque l'on tourne à OFF le switch IES statut sur la boîte de test.

10.1 Light load high voltage test / Essais haute tension et faible charge



Safety instructions for all high voltage tests
Consignes de sécurité pour tous les tests à la haute tension



WARNING : The following tests require high voltages. Use all required mandatory safety rules when working with high voltages (ie : operator's habilitation, earthing switch operation, presence of case covers, etc...)

Attention : La haute tension est requise pour les tests suivants. Utiliser toutes les règles de sécurité exigées (par ex : habilitation opérateur, mise à la terre, présence des couvercles, etc..)

- Before proceeding to the following tests, switch OFF the control electronic to delete any forced variable due to previous tests. To do it, switch OFF the **Battery Presence** and **Battery ON** on the control desk.

Avant de commencer les test suivants, veuillez reseter l'électronique de commande afin de remettre à leur état initial les variables forcées dans les tests précédents.

- Replace the FAN cover by a transparent cover.
Remplacer le couvercle du ventilateur par un couvercle transparent.
- Close all covers.
Fermer tous les couvercles.

11 Before starting / Avant de démarrer

Tests conditions *Conditions de tests*

- Start the low volatge by: switching ON **Battery Presence** and **Battery ON** on the control desk and then, switch ON **Battery contactor closing** on the test box.
Actionner le bouton poussoir "Battery contactor closing" sur le banc de test.
- Establish dialogue with the electronic by MMAP.
Etablir le dialogue avec MMAP
- Open the file "**I-O Check.tdb**".and check the following values:
Ouvrir le fichier "I-OChek.tdb" et verifier les valeurs suivantes:

| Preliminary / Préliminaire | | | | |
|--|---|---|--|--------------------------------|
| Item | Software name <i>Nom variable software</i> | Operating point <i>Mesure attendue</i> | PC reading <i>Lecture PC (MMAP)</i> | Passed / Correct (OK / NOK) |
| Air Flow sensor <i>Sonde de débit air</i> | MesSAirFanD6bmA | 4mA | 4mA | PASSED |

| | | | | |
|---|---------------|-------------------------------------|--|---|
|  | Page 31 of 46 | CODE DTR0000970658 | FINAL TEST CERTIFICATE AU_CVS 437 | DTR0100034034 Rev: C |
|---|---------------|-------------------------------------|--|---|

| Preliminary / Préliminaire | | | | |
|--|---|---|--|---------------------------------------|
| Item | Software name <i>Nom variable software</i> | Operating point <i>Mesure attendue</i> | PC reading <i>Lecture PC (MMAP)</i> | Passed / Correct (OK / NOK) |
| Inverter Module temperature <i>Température module onduleur</i> | MesTINV.D2b | Mes TINV,= Tambient | 26°C | PASSED |
| Battery charger module temperature <i>Température module chargeur batterie.</i> | MesTbcD2b | MesTBC = Tambient | 21°C | PASSED |

Check the events log on MMAP:

- Click on Tools/Events and on OK. Then select AA3_FAULTS in the list:

Vérifier la pile d'événements sur MMAP / Tools / Events / AA3_FAULTS :

| PC Reading the log event after start <i>Lecture PC du fichier événement après démarrage</i> | Passed / Correct (OK / NOK) |
|--|---------------------------------------|
| Check that this fault is not present in the log event <i>Vérifier que ce défaut n'est pas présent dans la pile d'événements</i> PC104 KO Présent 1 Problem with PC104 extension board If this fault is present, the card Ethernet of electronic is defect. <i>Si ce défaut est présent, la carte Ethernet est défectueuse.</i> | OK |

| These covers have to be present for tests / <i>Ces couvercles doivent être présents pour les tests</i> | Cover present / <i>Couvercle présent</i> (Y / N) | Passed / Correct (OK / NOK) |
|---|---|---------------------------------------|
| Cover under the inverter module <i>Couvercle sous le module onduleur</i> | y | OK |
| Cover and filter of the inverter module <i>Ensemble filtre module onduleur</i> | y | OK |
| Cover under the battery charger <i>Couvercle sous le module chargeur batterie</i> | y | OK |
| Cover and filter of the battery charger module <i>Ensemble filtre module chargeur de batterie</i> | y | OK |
| Cover under the GMV <i>Couvercle sous le ventilateur GMV</i> | y | OK |
| Cover under capacitor IOFC <i>Couvercle sous le condensateur IOFC</i> | y | OK |
| Cover under transformer IOT <i>Couvercle sous le transformateur IOT</i> | y | OK |

| | | | | |
|---|----------------------|-------------------------------|--|---------------------------------|
|  | <p>Page 32 of 46</p> | <p>CODE DTR0000970658</p> | <p>FINAL TEST CERTIFICATE AU_CVS 437</p> | <p>DTR0100034034 Rev: C</p> |
|---|----------------------|-------------------------------|--|---------------------------------|

12 Backup mode check / Vérification du mode Backup

Tests conditions: High voltage and DC and AC loads connected

Conditions de tests: Haute tension et charges AC et DC connectées

- Electronic started and communication established with MMAP as previous step.
L'électronique doit être démarrée et la connexion établie comme précédemment.
- Open the file "**Synoptique_PRASA.tdb**", click on the glasses and open the HTML page.
Ouvrir le fichier "Synoptique_PRASA.tdb" dans MMAP
- Check that there is no **Permanent Fault** before starting the CVS.
Verifier qu'il n'y a pas de défaut permanent avant de démarrer le CVS
- Provide High Voltage to the CVS : / *Fournir la haute tension au CVS*

On the control desk, switch ON the following switches:

- **Start Saftey Loop**, make sure the test area is clear,
- **K400**
- **OUT of earth mode**
- **HVPS Authorisation**

On the HVPS remote control (if orange LED ready to start is ON):

- **Start**
- **Close HVC**

- Increase the voltage to 3300 Vdc (+100V / -100V) by pushing the button **V+**
Enclencher la haute tension : 3300 Vdc (+100V / -100V)
- Set the following inputs on the test box :

Basculer les entrées suivantes sur le banc de test:

- **AuxCod1 = 1** and **AuxCod2 = 0**
- **IES_STATUS = 1** (IES in position POWER / *IES en position POWER*)
- **LI_Backup = 0**
- **LI_BYPASS = 0**
- **StatusHSCB (Start CVS) = 1** **THE CVS WILL START**

After one minute, connect the loads: / *Connecter les charges après 1 minute*

- AC Loads :
 - Switch on position **2** the **AC Loads** selector on the control desk
- DC Loads :
 - Switch OFF the **Battery ON** and the **Battery Presence**
 - Switch ON **1kW load** on the battery simulator remote and **DC Load ON** on the control desk

12.1.1.1

Phase rotation test./Vérification du champ tournant

| | |
|---------------|--------------------------------|
| Test / Action | Passed / Correct (OK / NOK) |
|---------------|--------------------------------|

| | | | | |
|---|----------------------|-------------------------------|--|---------------------------------|
|  | <p>Page 33 of 46</p> | <p>CODE DTR0000970658</p> | <p>FINAL TEST CERTIFICATE AU_CVS 437</p> | <p>DTR0100034034 Rev: C</p> |
|---|----------------------|-------------------------------|--|---------------------------------|

Check the phase rotation sequence on the AC output terminals XU-XV-XW
With an oscilloscope or any other measurement tool.

Vérifier que le champ tournant à la sortie du CVS correspond à XU-XV-XW

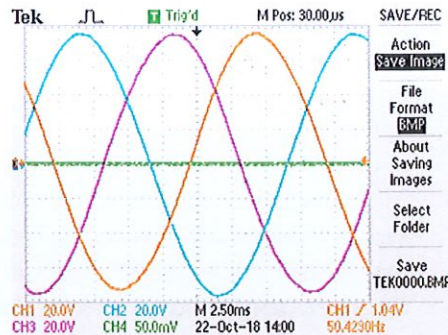

OK

12.1.1.2

Fan rotation test / Vérification du sens de rotation du GMV

Stop the CVS

Arrêter le CVS

- Disconnect the AC and DC loads:
 - Switch off **AC loads** position 0,
 - Switch off **DC Load**,
 - Switch off **1kW load** (battery simulator remote control)
- Stop the CVS:
 - Switch off **StatusHSCB** (Start CVS) = 0 on the test box.
- Stop High voltage:
 - Push **Open HVC** button (battery simulator remote control)
 - Push **Stop** button (battery simulator remote control)
 - Switch off **HVPS Authoristaion**
- Push **Discharge/Earth mode** button

| Test / Action | Passed / Correct (OK / NOK) |
|---|-----------------------------|
| <p>Check visually the direction of the rotation underneath the CVS <i>Vérifier visuellement que le ventilateur tourne dans le sens indiqué.</i></p>  | <p>OK</p> |

| | | | | |
|---|---------------|-------------------------------------|---|---|
|  | Page 34 of 46 | CODE DTR0000970658 | FINAL TEST CERTIFICATE AU_CVS 437 | DTR0100034034 Rev: C |
|---|---------------|-------------------------------------|---|---|

Restart the CVS
Redémarrer le CVS

Once is done, repeat the operation restart the CVS with high voltage. Then:

- Open the file "**I-O Checks.tdb**"
Ouvrir le fichier "I-O Checks" dans MMAP
- Fill the following tabs with all the values displayed
Remplir le tableau avec les valeurs affichées.
- Test duration : at least 30 minutes (in a row)
Durée de ce test (rodage): au moins 30 minutes de suite.

12.1.1.3

Characteristics / Relevé des caractéristiques

| Backup Mode / Mode backup | | | | | |
|---------------------------|---|---|---|--|---------------------------------------|
| Item | Software name <i>Nom variable software</i> | Expecting value <i>Mesure attendue</i> | Software values <i>Valeurs logicielles</i> | Multimeter/test bench <i>Banc de test</i> | Passed / Correct <i>(OK / NOK)</i> |
| LVMD input voltage | MesUdcInSivD2b | 3KV ± 300 V | 2941V | 2980V | PASSED |
| IOND-R | MeslacOutPh1INV.D6b | 45 A ± 15 A | 46A | | PASSED |
| IOND-S | MeslacOutPh2INV.D6b | 45 A ± 15 A | 46A | | PASSED |
| IOND-T | MeslacOutPh3INV.D6b | 45 A ± 15 A | 46A | | PASSED |
| AOCMD1 | MeslacOutPh1SivD6b | 20 A to 60 A | 55A | | PASSED |
| AOCMD2 | MeslacOutPh2SivD6b | 20 A to 60 A | 55A | | PASSED |
| AOCMD3 | MeslacOutPh3SivD6b | 20 A to 60 A | 55A | | PASSED |
| AOVMD1 | MesUacOutSivPh1D6b | 400 V ± 20 V | 400V | | PASSED |
| AOVMD2 | MesUacOutSivPh2D6b | 400 V ± 20 V | 400V | | PASSED |
| Output Frequency | | 50 Hz ± 0.5 Hz | | 50Hz | PASSED |
| THD | | < 8% | | 8% | PASSED |
| IBCM-R | MeslacInPh1BCD6b | 50 A ± 15 A * | 11A | | PASSED |

| | | | | |
|---|----------------------|--------------------------------------|---|--|
|  | <p>Page 35 of 46</p> | <p>CODE DTR0000970658</p> | <p>FINAL TEST CERTIFICATE AU_CVS 437</p> | <p>DTR0100034034 Rev: C</p> |
|---|----------------------|--------------------------------------|---|--|

| Backup Mode / Mode backup | | | | | |
|---------------------------|---|---|---|--|---------------------------------------|
| Item | Software name <i>Nom variable software</i> | Expecting value <i>Mesure attendue</i> | Software values <i>Valeurs logicielles</i> | Multimeter/test bench <i>Banc de test</i> | Passed / Correct <i>(OK / NOK)</i> |
| IBCM-S | MesIacInPh2BCD6b | 50 A ± 15 A * | 11A | | PASSED |
| IBCM-T | MesIacInPh3BCD6b | 50 A ± 15 A * | 11A | | PASSED |
| IBAT | MesIacOutBatD2b | 0 < I _{bat} < 10 A* | 0.356A | 0.2A | PASSED |
| IBAT + I CH DC | | 10 A ± 5 A | | 6.7A | PASSED |
| Battery voltage | MesUdcInBatD2b | 126.9 V ± 2.5 V At 20°C | 126V | 126.1V | PASSED |
| Air Flow sensor | MesSAirFanD6bmA | 14 < Meas < 18mA | 664l/s | | PASSED |
| INV. module temp. | MesTINV.D2b | 15 < T < 40 °C | 26°C | | PASSED |
| INV. module temp. | MesTbcD2b | 15 < T < 40 °C | 21°C | | PASSED |
| Test duration | NA | T > 30 minutes | | 60Min | PASSED |

(*): The battery current value depends on the battery load state. The reference value of MesIacInPh~~x~~BCD6b is for a battery full loaded.

La valeur de courant dépend de l'état de charge de la batterie. La valeur de référence de MesIacInPh~~x~~BCD6b est indiquée pour une batterie charge terminée. Reprendre ces valeurs lorsque la batterie est bien chargée

| | | | | |
|---|----------------------|-------------------------------|--|---------------------------------|
|  | <p>Page 36 of 46</p> | <p>CODE DTR0000970658</p> | <p>FINAL TEST CERTIFICATE AU_CVS 437</p> | <p>DTR0100034034 Rev: C</p> |
|---|----------------------|-------------------------------|--|---------------------------------|

During this test check that the following outputs state.

Pendant le test, vérifier que les sorties suivantes correspondent à l'état attendu.

| Outputs <i>Sorties</i> | State <i>Etat</i> | Observed values <i>Valeurs observée</i> | Passed / Correct <i>(OK / NOK)</i> |
|---------------------------|----------------------|--|---------------------------------------|
| AOIK_Status | 1 | 1 | OK |
| FCK_Status | 1 | 1 | OK |
| SHSK_Status | 0 | 0 | OK |
| NPK_Status | 1 | 1 | OK |

13 Reversible mode check / Vérification du mode réversible

Tests conditions

Conditions de tests

- Electronic started and communication established with **MMAP** as previous step.
L'électronique doit être démarrée et la connexion établie comme précédemment.
- Open the file "**Synoptique_PRASA.tdb**", click on the glasses and open the HTML page.
Ouvrir le fichier "Synoptique_PRASA.tdb" dans MMAP.
- Check that there is no **Permanent Fault** before starting the CVS.
Vérifier qu'il n'y a pas de défaut permanent avant de démarrer le CVS
On the control desk, switch ON the following switches:
 - **Start Saftey Loop**, make sure the test area is clear,
 - **K400**
 - **OUT of earth mode**
- Set the following inputs on the test box :
Basculer les entrées suivantes sur le banc de test:
 - **AuxCod1 = 1** and **AuxCod2 = 0**
 - **IES_STATUS = 1** (IES in position POWER / *IES en position POWER*)
 - **LI_Backup = 0**
 - **LI_BYPASS = 0**
 - **StatusHSCB = 0**
- Open the file "**Reversible.tdb**"
Ouvrir le fichier "Reversible.tdb" dans MMAP
 - Force the variable **NRG_AcuiData1_test = 2**
Forcer la variable NRG_AcuiData1_test = 2
 - Force the variable **NRG_AcuData1_test = 2**
Forcer la variable NRG_AcuData1_test = 2
 - Force the variable **Ethernet_test = 1** (Battery charger is ON) **THE CVS WILL START**
Forcer la variable Ethernet_test = 1 (Chargeur batterie est ON)

After one minute, connect the loads:

| | | | | |
|---|---------------|-------------------------------------|--|---|
|  | Page 37 of 46 | CODE DTR0000970658 | FINAL TEST CERTIFICATE AU_CVS 437 | DTR0100034034 Rev: C |
|---|---------------|-------------------------------------|--|---|

- AC Loads :
 - Switch on position 1 "**Reverse load**" the AC loads selector on the control desk
- Fill the following tabs with all the values displayed
Remplir le tableau avec les valeurs affichées.
- Test duration : at least 2 minutes (in a row)
Durée de ce test (rodage) : au moins 2 minutes de suite.

13.1.1.1

Characteristics / Caractéristiques.

| Reversible Mode / Mode réversible | | | | | |
|--|---|---|---------------------------------------|---|--------------------------------|
| Item | Software name <i>Nom variable software</i> | Operating point <i>Mesure attendue</i> | PC reading <i>Lecture PC(MMAP)</i> | Multimeter / test bench readings <i>Lecture appareils banc de test</i> | Passed / Correct (OK / NOK) |
| AOCMD1 | MesIacOutPh1SivD6b | 5 A ± 3A | 2A | | PASSED |
| AOCMD2 | MesIacOutPh2SivD6b | 5 A ± 3A | 2A | | PASSED |
| AOCMD3 | MesIacOutPh3SivD6b | 5 A ± 3A | 2A | | PASSED |
| AOVMD1 | MesUacOutSivPh1D6b | 400 V ± 60 V | 401V | | PASSED |
| AOVMD2 | MesUacOutSivPh2D6b | 400 V ± 60 V | 400V | | PASSED |
| Output Frequency <i>Fréquence de sortie</i> | | 50 Hz ± 0.5 Hz | | 50Hz | PASSED |
| IBCM-R | MesIacInPh1BCD6b | 90 A to 152 A * 90 A à 152 A * | 112A | | PASSED |
| IBCM-S | MesIacInPh2BCD6b | 90 A to 152 A * 90 A à 152 A * | 120A | | PASSED |
| IBCM-T | MesIacInPh3BCD6b | 90 A to 152 A * 90 A à 152 A * | 121A | | PASSED |
| IBAT | MesIdcOutBatD6b | -50 A ± 25 A | -34A | -34.4A | PASSED |
| Battery voltage <i>Tension batterie</i> | MesUdcInBatD6b | 95 V < Ubat < 135 V | 124V | 124.7V | PASSED |
| Test duration <i>Durée du test</i> | NA | T > 2 minutes | | 5MIN | PASSED |

* A larger criteria is due to a disparity of magnetising inductance (between 200 to 240mH).
Ce grand critère est dû à la disparité de la self de magnétisation (entre 200 à 240 mH).

During the test check that the following outputs state.
Pendant le test, vérifier que les sorties suivantes correspondent à l'état attendu.

| | | | | |
|---|-------------------------------------|---|---|---|
|  | <p align="center">Page 38 of 46</p> | <p align="center">CODE DTR0000970658</p> | <p align="center">FINAL TEST CERTIFICATE AU_CVS 437</p> | <p align="center">DTR0100034034 Rev: C</p> |
|---|-------------------------------------|---|---|---|

| Outputs <i>Sorties</i> | State <i>Etat</i> | Observed values <i>Valeurs observée</i> | Passed / Correct <i>(OK / NOK)</i> |
|---------------------------|----------------------|--|---------------------------------------|
| AOIK_Status | 1 | 1 | OK |
| FCK_Status | 0 | 0 | OK |
| SHSK_Status | 0 | 0 | OK |
| NPK_Status | 1 | 1 | OK |

Stop the CVS:

Arrêter le CVS:

- Disconnect the AC Loads:
Basculer les entrées suivantes sur le banc de test
 - Switch off the **Reversible AC loads**
- Stop the CVS:
 - Force the variable **Ethernet_test** = 0
Forcer la variable Ethernet_test = 0
- Stop the battery voltage:
Couper la tension batterie
 - Switch off **Battery ON**
 - Switch off **Presence Battery**
- Put the Safety / Earth mode:
Couper la tension batterie
 - Push the **Discharge/Earth Mode** button

14 Shore supply mode check / Vérification du mode prise de quai.

Tests conditions: No High Voltage and no AC Loads

Conditions de tests: Sans Haute tension ni charges AC

- Electronic started and communication established with **MMA** as previous step.
L'électronique doit être démarrée et la connexion établie comme précédemment.
- Open the file "**Synoptique_PRASA.tdb**", click on the glasses and open the HTML page.
Ouvrir le fichier "Synoptique_PRASA.tdb" dans MMA
- Check that there is no **Permanent Fault** before starting the CVS.
Vérifier qu'il n'y a pas de défaut permanent avant de démarrer le CVS
- Go and connect the **Shore Supply plug** on the CVS
Aller connecter la Prise de Quai sur le CVS
- Set the following inputs on the test box :
Basculer les entrées suivantes sur le banc de test:
 - **AuxCod1** = 1 and **AuxCod2** = 0
 - **IES_STATUS** = 1 (IES in position POWER / *IES en position POWER*)
 - **LI_Backup** = 0

| | | | | |
|---|----------------------|-------------------------------------|--|---|
|  | Page 39 of 46 | CODE DTR0000970658 | FINAL TEST CERTIFICATE AU_CVS 437 | DTR0100034034 Rev: C |
|---|----------------------|-------------------------------------|--|---|

- **LI_BYPASS** = 0
- **StatusHSCB** =0
- Supply the CVS with 400V by the Shore Supply :
Alimenter le CVS en 400V avec la prise de quai
On the control desk, swith ON the following switches:
 - **Start Saftey Loop**, make sure the test area is clear,
 - **K400**
 - **OUT of earth mode**
 - **Shore Supply Mode** **THE CVS WILL START**

After one minute, connect the loads:

- DC Loads :
 - Switch OFF the **Battery ON** and the **Battery Presence**
 - Switch ON the **1kW load** on the battery simulator remote control and the **DC Load ON** on the control desk
- Test duration : at least 2 minutes (in a row)
Durée de ce test (rodage) : au moins 2 minutes de suite.

14.1.1.1

Characteristics / Caractéristiques.

| Shore supply Mode / Mode prise de quai | | | | | |
|--|---|---|---------------------------------------|---|---------------------------------------|
| Item | Software name <i>Nom variable software</i> | Operating point <i>Mesure attendue</i> | PC reading <i>Lecture PC(MMAP)</i> | Multimeter / test bench readings <i>Lecture appareils banc de test</i> | Passed / Correct <i>(OK / NOK)</i> |
| AOCMD1 | MeslacOutPh1SivD6b | 20 Aac ± 5A | 18A | | PASSED |
| AOCMD2 | MeslacOutPh2SivD6b | 20 Aac ± 5A | 19A | | PASSED |
| AOCMD3 | MeslacOutPh3SivD6b | 20 Aac ± 5A | 19A | | PASSED |
| AOVMD1 | MesUacOutSivPh1D6b | 400 V ± 50 V | 408V | | PASSED |
| AOVMD2 | MesUacOutSivPh2D6b | 400 V ± 50 V | 408V | | PASSED |
| Input Frequency <i>Fréquence d'entrée</i> | | 50 Hz ± 0.5 Hz | 50Hz | | PASSED |
| IBCM-R | MeslacInPh1BCD6b | 15 A ± 7 A | 11A | | PASSED |
| IBCM-S | MeslacInPh2BCD6b | 15 A ± 7 A | 11A | | PASSED |
| IBCM-T | MeslacInPh3BCD6b | 15 A ± 7 A | 11A | | PASSED |

| | | | | |
|---|----------------------|-------------------------------------|--|---|
|  | Page 40 of 46 | CODE DTR0000970658 | FINAL TEST CERTIFICATE AU_CVS 437 | DTR0100034034 Rev: C |
|---|----------------------|-------------------------------------|--|---|

| Shore supply Mode / Mode prise de quai | | | | | |
|--|---|---|---------------------------------------|---|---------------------------------------|
| Item | Software name <i>Nom variable software</i> | Operating point <i>Mesure attendue</i> | PC reading <i>Lecture PC(MMAP)</i> | Multimeter / test bench readings <i>Lecture appareils banc de test</i> | Passed / Correct <i>(OK / NOK)</i> |
| I CH DC | MesI dcOutBc2b | 8 A ± 4 A | 8.845A | 6.7A | PASSED |
| Battery voltage <i>Tension batterie</i> | MesU dcInBatD6b | 126.9 V ± 2.5 V At 20°C | 126V | 126.1V | PASSED |
| Test duration <i>Durée du test</i> | NA | T > 2 minutes | | 5min | PASSED |

During the test check that the following outputs state.

Pendant le test, vérifier que les sorties suivantes correspondent à l'état attendu.

| Outputs <i>Sorties</i> | State <i>Etat</i> | Observed values <i>Valeurs observée</i> | Passed / Correct <i>(OK / NOK)</i> |
|---------------------------|----------------------|--|---------------------------------------|
| AOIK_Status | 1 | 1 | OK |
| FCK_Status | 0 | 0 | OK |
| SHSK_Status | 1 | 1 | OK |
| NPK_Status | 0 | 0 | OK |

To stop the converter, switch off the supply 400Vac on shore supply.

Pour stopper le convertisseur, déclencher l'alimentation de la prise de quai.

| DEPARTMENT <i>Département</i> | NAME (S) <i>Nom(s)</i> | Function <i>Fonction</i> | DATE <i>Date</i> | RESULTS |
|-------------------------------|---------------------------------------|-----------------------------|---------------------|---------|
| ALSTOM UBUNYE TRACTION | KHUTSO MATLEJOANE THULANI MIYA | FUNCTIONAL TEST | 10/07/2024 | PASSED |

| | | | | |
|---|----------------------|-------------------------------|--|---------------------------------|
|  | <p>Page 41 of 46</p> | <p>CODE DTR0000970658</p> | <p>FINAL TEST CERTIFICATE AU_CVS 437</p> | <p>DTR0100034034 Rev: C</p> |
|---|----------------------|-------------------------------|--|---------------------------------|

Stop the CVS:

Arrêter le CVS:

- Disconnect the DC Loads:
Deconnecter les charges DC :
 - Switch off the **DC Loads**
 - Switch off the **1kW load**
- Stop the CVS:
 - Switch off the **Shore Supply Mode**
- Put the Safety / Earth mode:
Mettre le CVS à la décharge/terre
 - Push the **Discharge/Earth Mode** button

15 Flat battery start check / Vérification démarrage sous batterie basse

Tests conditions: No High Voltage and no AC Loads, Shore Supply still connected

Conditions de tests: Sans Haute tension ni charges AC et prise de quai toujours connectée

- Electronic started and communication established with **MMAP** as previous step.
L'électronique doit être démarrée et la connection établie comme précédement.
- Open the file "**Synoptique_PRASA.tdb**", click on the glasses and open the HTML page.
Ouvrir le fichier "Synoptique_PRASA.tdb" dans MMAP
- Check that there is no **Permanent Fault** before starting the CVS.
Verifier qu'il n'y a pas de défaut permanent avant de démarrer le CVS
- Set the following inputs on the test box :
Basculer les entrées suivantes sur le banc de test:
 - **AuxCod1** = 1 and **AuxCod2** = 0
 - **IES_STATUS** = 1 (IES in position POWER / *IES en position POWER*)
 - **LI_Backup** = 0
 - **LI_BYPASS** = 0
 - **StatusHSCB** = 0
- Stop the battery voltage:
Couper la tension batterie
 - Switch off **Battery ON**
 - Switch off **Presence Battery**

| | | | | |
|---|----------------------|-------------------------------|--|---------------------------------|
|  | <p>Page 42 of 46</p> | <p>CODE DTR0000970658</p> | <p>FINAL TEST CERTIFICATE AU_CVS 437</p> | <p>DTR0100034034 Rev: C</p> |
|---|----------------------|-------------------------------|--|---------------------------------|

15.1.1.1

Tests / tests.

| Action <i>Action</i> | Check <i>Vérification</i> | Passed / Correct (OK / NOK) |
|--|---|--------------------------------|
| Battery voltage decrease <i>La tension batterie diminue</i> | Wait and check to see the control electronic switching off <i>Vérifier que l'électronique de contrôle est hors tension</i> | OK |
| Switch ON the Shore Supply Mode <i>Activer le mode prise de quai</i> | Check that the control electronic is switching ON <i>Vérifier que l'électronique de contrôle est sous tension</i> After a moment, THE CVS WILL START | OK |
| Establish the communication with MMAP and open the file " Synoptique_PRASA.tdb " <i>Ouvrir le fichier "Synoptique_PRASA.tdb" dans MMAP</i> | Check that the Battery Charger is ON <i>Vérifier que le chargeur batterie est fonctionnant</i> | OK |
| Test duration : at least 2 minutes (in a row) <i>Durée de ce test (rodage) : au moins 2 minutes de suite.</i> | 4MIN | OK |

Stop the CVS:

Arrêter le CVS:

- Stop the CVS:
 - Switch off the **Shore Supply Mode**
- Put the Safety / Earth mode:
 - Push the **Discharge/Earth Mode** button
- Go and disconnect the Shore Supply Plug
 - *Aller et déconnecter la prise de quai*

15.2 Safety requirements / Exigences de sécurité

16 Input and output capacitor discharge

Décharge des condensateurs d'entrée et sortie.

The converter has to be operated until steady-state operation in nominal working conditions. The converter is turned off and the voltage across the input filter capacitors has to decrease in a given time.

Le convertisseur doit être sous tension dans les conditions nominales. Le convertisseur est coupé et la tension des condensateurs de filtre d'entrée doit être sous une tension donnée dans un temps donné

Tests conditions: High voltage and DC and AC loads connected

Conditions de tests: Haute tension et charges AC et DC connectées

- Electronic started and communication established with MMAP as previous step.
L'électronique doit être démarrée et la connexion établie comme précédemment.
- Open the file "**Synoptique_PRASA.tdb**", click on the glasses and open the HTML page.
Ouvrir le fichier "Synoptique_PRASA.tdb" dans MMAP
- Check that there is no **Permanent Fault** before starting the CVS.
Vérifier qu'il n'y a pas de défaut permanent avant de démarrer le CVS

| | | | | |
|---|----------------------|--------------------------------------|--|---------------------------------|
|  | <p>Page 43 of 46</p> | <p>CODE DTR0000970658</p> | <p>FINAL TEST CERTIFICATE AU_CVS 437</p> | <p>DTR0100034034 Rev: C</p> |
|---|----------------------|--------------------------------------|--|---------------------------------|

- Provide High Voltage to the CVS :
Fournir la haute tension au CVS
On the control desk, switch ON the following switches:
 - **Start Saftey Loop**, make sure the test area is clear,
 - **K400**
 - **OUT of earth mode**
 - **HVPS Authorisation**
 On the HVPS remote control (if orange LED ready to start is ON):
 - **Start**
 - **Close HVC**
- Increase the voltage to 3300 Vdc (+100V / -100V) by pushing **V+**
Enclencher la haute tension : 3300 Vdc (+100V / -100V)
- Set the following inputs on the test box :
Basculer les entrées suivantes sur le banc de test:
 - **AuxCod1 = 1 and AuxCod2 = 0**
 - **IES_STATUS = 1** (IES in position POWER / *IES en position POWER*)
 - **LI_Backup = 0**
 - **LI_BYPASS = 0**
 - **StatusHSCB (Start CVS) = 1** **THE CVS WILL START**

After two minute, stop the CVS and High Voltage:

Après 2 minutes, arrêter le CVS et la haute tension:

- Stop the CVS:
 - Switch off **StatusHSCB** (Start CVS) = 0 on the test box.
- Stop High voltage:
 - Push **Open HVC** button (battery simulator remote control)
 - Push **Stop** button (battery simulator remote control)
 - Switch off **HVPS Authoristaion**
- **Do not push** Discharge/Earth mode button

Now wait 600 second and check the following measurements on MMAP:

| Test <i>Test</i> | Criteria <i>Critères</i> | Observed values <i>valeurs lues</i> | Passed / Correct (OK / NOK) |
|--|------------------------------------|---|--|
| MesUdcInSivD6b | Measure < 70V after 600 Sec | oV | OK |
| Measure on test bench "U batt" <i>Mesurer de la tension batterie « U batt » sur le banc de test</i> | Measure < 70V after 600 Sec | oV | OK |

17 Ground continuity test / Test de continuité des masses.

Check the earth continuity between the external M10 earth connections and all case covers.

| | | | | |
|---|----------------------|-------------------------------|--|---------------------------------|
|  | <p>Page 44 of 46</p> | <p>CODE DTR0000970658</p> | <p>FINAL TEST CERTIFICATE AU_CVS 437</p> | <p>DTR0100034034 Rev: C</p> |
|---|----------------------|-------------------------------|--|---------------------------------|

Vérifier la continuité de masse entre la connexion de mise à la masse externe M10 et tous les couvercles

Check of the frame earth continuity between a two random screw cover and earth stud M10 on assembly case.

Vérifier la continuité de chaque couvercle entre deux vis de fixation prise au hasard et la masse externe M10.

The method used is a current injection between the reference point « Stud earth » and another points « B » on the frame.

La méthode utilisée est l'injection de courant entre la référence "masse externe" et un autre point "B" du coffre

With the voltage drop and the current measurement between these points we can calculate the earth continuity resistance

Avec la tension mesurée et le courant injecté entre chaque point, on peut calculer la résistance

The current injected have to be min 50A, Criteria $R < 30\text{ m}\Omega$

Le courant injecté doit au minimum de 50 A et le critère de résistance est $R < 30\text{ m}\Omega$

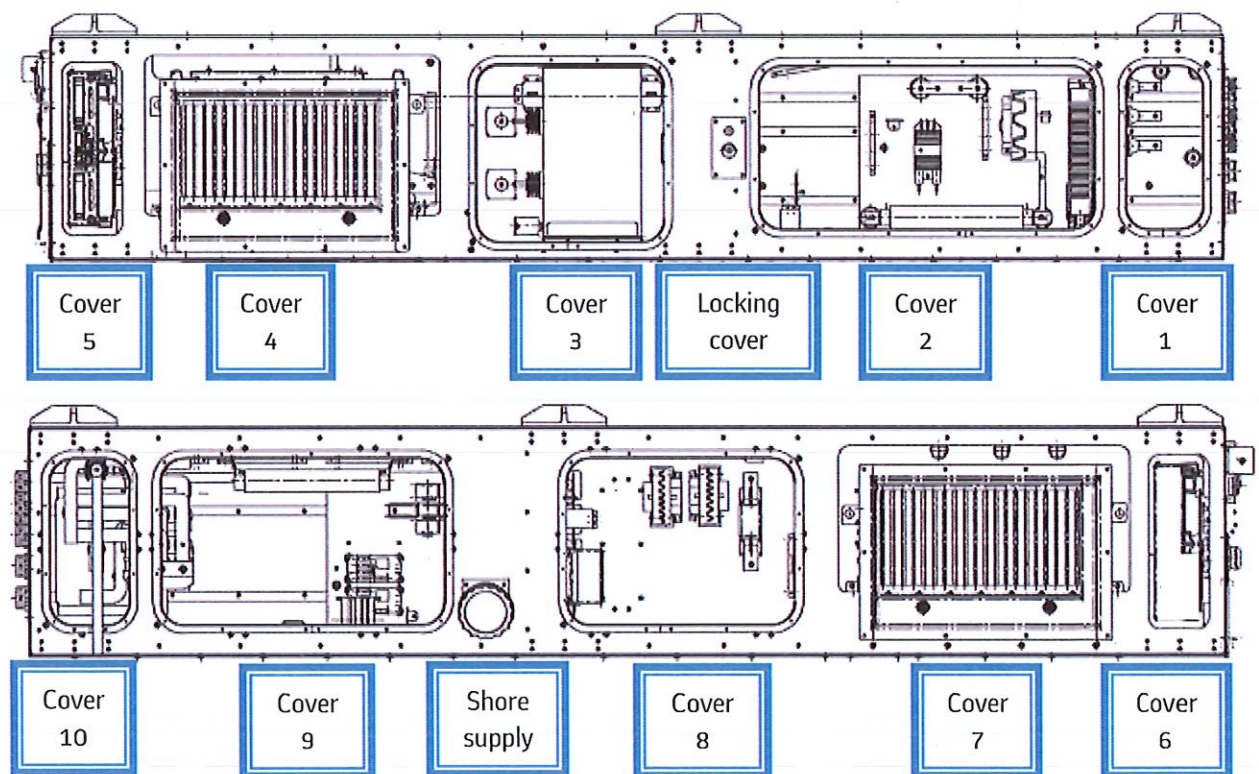

| | | | | |
|---|---------------|-------------------------------------|--|---|
|  | Page 45 of 46 | CODE DTR0000970658 | FINAL TEST CERTIFICATE AU_CVS 437 | DTR0100034034 Rev: C |
|---|---------------|-------------------------------------|--|---|

| Earth continuity between <i>Continuité entre masse et</i> | Injected current <i>Courant injecté</i> (A) | Voltage measure <i>Tension mesurée</i> (mV) | Impedance <i>Impédance</i> (mΩ) | Criterion <i>Critère</i> | Passed / Correct (OK / NOK) |
|---|---|---|---|------------------------------------|--|
| Earth stud and cover 1 <i>Mise à la masse et couvercle 1</i> | | | | | |
| Screw 1 <i>Vis 1</i> | 43.5A | 1.26mV | 0.030Ω | Meas < 30 mΩ Mesure < 30mΩ | PASSED |
| Screw 2 <i>Vis 2</i> | 43.5A | 1.18mV | 0.027Ω | Meas < 30 mΩ Mesure < 30mΩ | PASSED |
| Earth stud and cover 2 <i>Mise à la masse et couvercle 2</i> | | | | | |
| Screw 1 <i>Vis 1</i> | 43.6A | 1.12mV | 0.026Ω | Meas < 30 mΩ Mesure < 30mΩ | PASSED |
| Screw 2 <i>Vis 2</i> | 43.4A | 1.13mV | 0.027Ω | Meas < 30 mΩ Mesure < 30mΩ | PASSED |
| Earth stud and locking cover <i>Mise à la masse et serrures</i> | | | | | |
| Screw 1 <i>Vis 1</i> | 43.5A | 1.64mV | 0.040Ω | Meas < 30 mΩ Mesure < 30mΩ | PASSED |
| Screw 2 <i>Vis 2</i> | 43.6A | 1.34mV | 0.031Ω | Meas < 30 mΩ Mesure < 30mΩ | PASSED |
| Earth stud and cover 3 <i>Mise à la masse et couvercle 3</i> | | | | | |
| Screw 1 <i>Vis 1</i> | 43.5A | 1.14mV | 0.027Ω | Meas < 30 mΩ Mesure < 30mΩ | PASSED |
| Screw 2 <i>Vis 2</i> | 43.5A | 1.19mV | 0.028Ω | Meas < 30 mΩ Mesure < 30mΩ | PASSED |
| Earth stud and cover 4 <i>Mise à la masse et couvercle 4</i> | | | | | |
| Screw 1 <i>Vis 1</i> | 43.5A | 1.04mV | 0.028Ω | Meas < 30 mΩ Mesure < 30mΩ | PASSED |
| Screw 2 <i>Vis 2</i> | 43.5A | 1.08mV | 0.027Ω | Meas < 30 mΩ Mesure < 30mΩ | PASSED |
| Earth stud and cover 5 <i>Mise à la masse et couvercle 5</i> | | | | | |
| Screw 1 <i>Vis 1</i> | 43.5A | 1.19mV | 0.027Ω | Meas < 30 mΩ Mesure < 30mΩ | PASSED |
| Screw 2 <i>Vis 2</i> | 43.5A | 1.13mV | 0.026Ω | Meas < 30 mΩ Mesure < 30mΩ | PASSED |
| Earth stud cover 6 <i>Mise à la masse et couvercle 6</i> | | | | | |
| Screw 1 <i>Vis 1</i> | 43.5A | 1.16mV | 0.027Ω | Meas < 30 mΩ Mesure < 30mΩ | PASSED |
| Screw 2 <i>Vis 2</i> | 43.4A | 1.13mV | 0.027Ω | Meas < 30 mΩ Mesure < 30mΩ | PASSED |
| Earth stud and cover 7 <i>Mise à la masse et couvercle 7</i> | | | | | |
| Screw 1 <i>Vis 1</i> | 43.5A | 1.08mV | 0.025Ω | Meas < 30 mΩ Mesure < 30mΩ | PASSED |
| Screw 2 <i>Vis 2</i> | 43.5A | 1.10mV | 0.026Ω | Meas < 30 mΩ Mesure < 30mΩ | PASSED |

| | | | | |
|---|----------------------|-------------------------------------|--|---|
|  RESTRICTED ALSTOM UBUNYE | Page 46 of 46 | CODE DTR0000970658 | FINAL TEST CERTIFICATE AU_CVS 437 | DTR0100034034 Rev: C |
|---|----------------------|-------------------------------------|--|---|

| Earth continuity between <i>Continuité entre masse et</i> | Injected current <i>Courant injecté</i> (A) | Voltage measure <i>Tension mesurée</i> (mV) | Impedance <i>Impédance</i> (mΩ) | Criterion <i>Critère</i> | Passed / <i>Correct</i> (OK / NOK) |
|---|---|---|---|-------------------------------|--|
| Earth stud and cover 8 <i>Mise à la masse et couvercle 8</i> | | | | | |
| Screw 1 <i>Vis 1</i> | 43.4A | 1.06mV | 0.026Ω | Meas < 30 mΩ Mesure < 30mΩ | PASSED |
| Screw 2 <i>Vis 2</i> | 43.5A | 1.06mV | 0.025Ω | Meas < 30 mΩ Mesure < 30mΩ | PASSED |
| Earth stud and cover shore supply <i>Mise à la masse et couvercle de la prise de quai</i> | | | | | |
| Cover shore supply <i>Couvercle prise de quai</i> | 43.6A | 1.15mV | 0.027Ω | Meas < 30 mΩ Mesure < 30mΩ | PASSED |
| Earth stud and cover 9 <i>Mise à la masse et couvercle 9</i> | | | | | |
| Screw 1 <i>Vis 1</i> | 43.6A | 1.07mV | 0.025Ω | Meas < 30 mΩ Mesure < 30mΩ | PASSED |
| Screw 2 <i>Vis 2</i> | 43.6A | 1.11mV | 0.026Ω | Meas < 30 mΩ Mesure < 30mΩ | PASSED |
| Earth stud and cover 10 <i>Mise à la masse et couvercle 10</i> | | | | | |
| Screw 1 <i>Vis 1</i> | 43.5A | 1.12mV | 0.026Ω | Meas < 30 mΩ Mesure < 30mΩ | PASSED |
| Screw 2 <i>Vis 2</i> | 43.5A | 1.13mV | 0.026Ω | Meas < 30 mΩ Mesure < 30mΩ | PASSED |

18 Identification sheet / Feuille d'identification

Refer to the current SIVPRASA Configuration Follow-up to check that the last applicable revision indexes of the different parts are correctly mounted.

Se référer au document de configuration du CVS PRASA pour vérifier les dernières révisions applicables des différentes sous-ensemble montés

| | Revision of document <i>Révision du document</i> | Passed / <i>Correct</i> (OK / NOK) |
|---|---|---------------------------------------|
| The file DLB (Delivery log Book) : DTR0100036744 should be completed <i>Le fichier DLC (Dossier Livraison Constructeur); DTR0100036744 doit être complété</i> | B | OK |
| The file (traceability list) DTR0100036746 should be completed <i>Le fichier (Liste tracabilité) DTR0100036746 doit être complété</i> | B | OK |

| DEPARTMENT <i>Département</i> | NAME (S) <i>Nom(s)</i> | Function <i>Fonction</i> | DATE <i>Date</i> | RESULTS |
|-------------------------------|------------------------------------|-----------------------------|---------------------|---------|
| ALSTOM UBUNYE TRACTION | THABO SISHANGE LUCKY KGWADI | COVER TEST | 11/07/2024 | PASSED |